

BOEHLERIT

Easytec

Stechen, Stechdrehen und Abstechen

Member of the LEITZ Group

Easytec

Grooving, Groove-turning
and Parting off







Stechen, Stechdrehen mit Easytec
Grooving, Groove-turning
with Easytec

Systemvorteile Easytec	Advantages of the System Easytec	4
Programmübersicht	Programm range	
Klemmhalter und Wendeplatten für das Abstechen und außen Einstechen	Tool holders and indexable inserts for parting and external grooving	6
Klemmhalter und Wendeplatten für das außen Einstechen, Stechdrehen, Profildrehen und Feinstechen	Tool holders and indexable inserts for external grooving, groove-turning, profiling and undercutting	6
Klemmhalter und Wendeplatten für das axial Einstechen und Stechdrehen	Tool holder and indexable inserts for face grooving and groove-turning	7
Klemmhalter und Wendeplatten für das innen Einstechen, Stechdrehen, Formdrehen und Freistechen	Tool holders and indexable inserts for internal grooving, groove-turning, profiling and undercutting	7
Spanformstufengeometrien	Chip former geometries	
für das Ein- und Abstechen	for parting and grooving	8
für das Stechen und Stechdrehen	for grooving and groove-turning	9
für das Profildrehen	for profile turning	9
für das Kopierdrehen von Aluminium	for copying aluminium	9
Bezeichnungssysteme	Designationssystem	
für Wendeschneidplatten	for indexable inserts	10
für Klemmhalter zur Außenbearbeitung	for tool holders, external machining	12
für Klemmhalter zur Innenbearbeitung	for tool holders, internal machining	14
Klemmhalter für Adaptersystem	tool holders for adapter system	16
Klemmhalter für Adapter und Adaptersystem	tool holders for adapter and adapter system	17
Wendeplatten	Inserts	18
Sonderprofilplatten	Inserts with special profile	30
Klingen	Parting blades	32
Spannblock	Parting holder	35
Klemmhalter	Tool holders	36
Bohrstangen	Boring bars	45
Klemmhalter und Bohrstangen zum Kopierdrehen	Toolholders and boring bars for copying aluminium wheels	47
Sicherungseinstiche	Circlip grooves	49
Adaptersysteme	Adapter systems	50
Technische Hinweise	Technical hints	52
Schnittdatenrichtwerte	Cutting data standard values	62
Vertriebsgesellschaften	Sales organisations	72

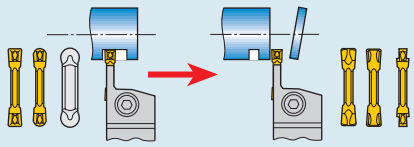

Kapfenberg BOEHLERIT Österreich, Austria

	<p>Stech- und Drehsystem zugleich reduziert Ihre Lagerhaltung. A grooving and turning system all in one. Reduces your stock.</p>
	<p>Einfacher Aufbau reduziert Fehlermöglichkeiten in der Anwendung. Simple setup. Reduces possibilities of errors in the application.</p>
	<p>Hohe Stabilität durch doppelte U-Führung und lange Schneidplatten erhöht Ihre Prozesssicherheit. High stability through double U-clamp and long inserts. Increases your process security.</p>
<p>DIN 912 (ISO)</p> 	<p>Ersatzteile sind Normteile, das reduziert Ersatzteilkosten. Spare parts are standard part. Reduces costs for spare parts.</p>

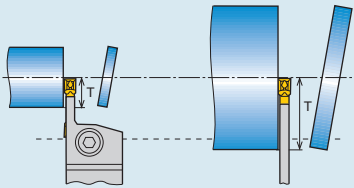
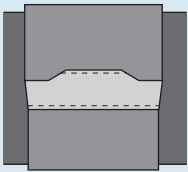
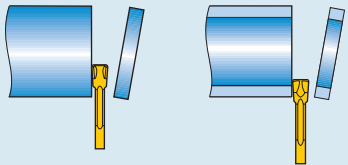
<p>Stechen mit Easytec Grooving with Easytec</p>	
	<p>Ein- und zweiseitige Schneidplatten: ES ... und ED ..., bei kleinen Stechtiefen noch wirtschaftlicher. Single and double ended inserts ES ... and ED ..., more economical with shallow grooving cuts.</p>
	<p>Direktgepresste Schneidplatten senken Ihre Produktionskosten. Directly pressed inserts reduce production costs.</p>
	<p>Drei Spanformergeometrien: GM, GF und UM. Für jede Anwendung die richtige Schneide. Three chip former geometries: GM, GF and UM. Inserts to suit all applications.</p>

	<p>Schräge Hauptschneide möglich: ...R4, ...L4, ...R6, ...L6, ...R15, ...L15. Reduziert Grat- und Butzenbildung Angled main cutting edge available ...R4, ...L4, ...R6, ...L6, ...R15, ...L15. Formation of sharp edges and burrs is reduced.</p>
---	--

Stechdrehen mit Easytec
Groove-turning with Easytec

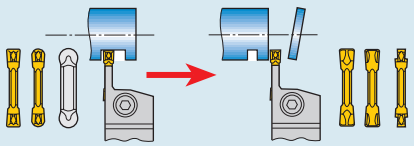
	<p>Ersetzt bis zu drei Werkzeuge und reduziert Ihre Lagerhaltung. It replaces up to 3 tools and reduces your stock.</p>
---	--

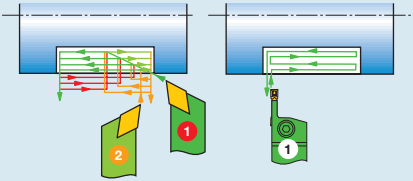

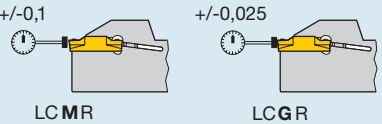

	<p>Eliminiert nahezu sämtliche Nebenzeiten. 95% statt 50% Eingriffszeit. Keine leeren Kilometer! Reduction of non cutting times. 95 % instead 50 % effective time. No empty miles!</p>
--	---

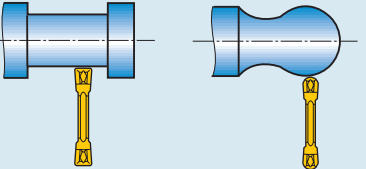
	<p>Direktgepresste und geschliffene Schneidplatten: ...LCMR..., ...LCGR... Für jede Aufgabe eine Lösung. Direct pressed and ground inserts: ...LCMR..., ...LCGR... A solution for any application.</p>
---	---

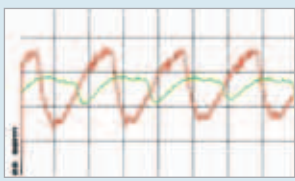
	<p>Drei Spanformergeometrien: TM, TA, RU. Für jede Anwendung die richtige Schneide. Two chip former geometries: TM, TA, RU Inserts to suit all applications.</p>
---	---

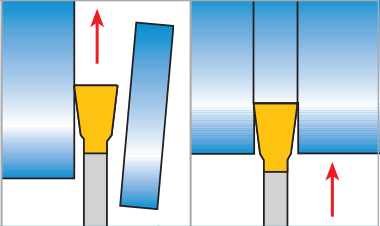
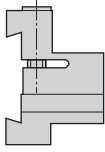
	<p>Gerade und runde Schneiden: ...LCGR..., ...RCGR... ob Sie Drehen oder Kopieren, – je nachdem. Straight and round cutting edges ...LCGR..., ...RCGR... – depending on whether the machining is turning or copying.</p>
---	--

	<p>Hohe Oberflächengüte beim Längsdrehen durch Wiper-Effekt erhöht Produktivität und ersetzt Schleifoperationen. High surface quality on longitudinal turning through wiper-effect. Increased productivity and may replace grinding.</p>
---	---

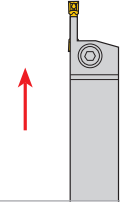
Abstechen und außen Einstechen Parting and external grooving					
Werkzeug Tool	PH...	PB...	PB...	CGFCR/L...E..D..	CGFCR/L...E...
Anstellwinkel Setting angle		0°	0°	0°	0°
Schnittrichtung Cutting direction					
Seite Page	35	32	33,34	36	38
Wendepplatten Indexable inserts		ED LC... ES LC...	ED LC... ES LC...	ED LC... ES LC...	ED LC...
Seiten Pages	-	18-29	18-29	18-29	18-29

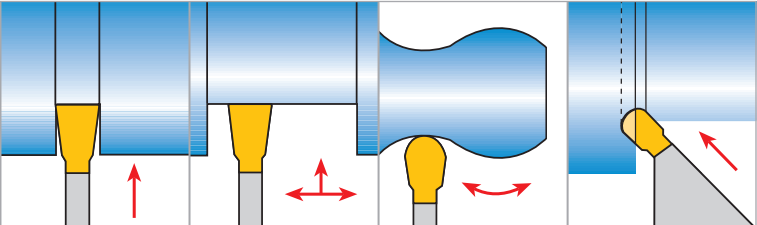
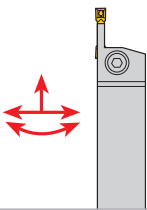
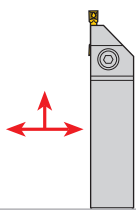
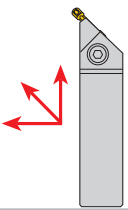
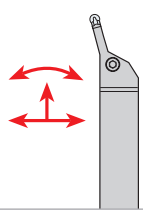
Außen Einstechen, Stechdrehen, Profildrehen und Freistechen External grooving, groove-turning, profiling and undercutting					
Werkzeug Tool	CGFCR/L...E...	CGFCR/L...F...	CGSCR/L...E...	CGKCR/L...E...	
Anstellwinkel Setting angle	0°	0°	45°	15°	
Schnittrichtung Cutting direction					
Seite Page	38	40-41,43	39	47	
Wendepplatten Indexable inserts	ED LC... ED RC...	ED LC... FD LC...	ED RC... ID RC...	ED RC...	
Seiten Pages	18-29	18-29	18-29	18-29	

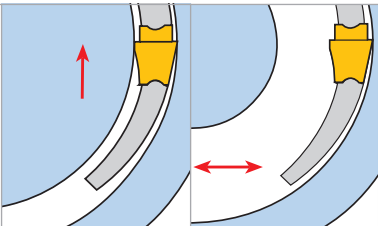
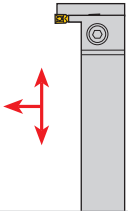
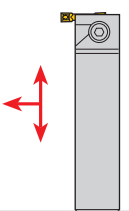
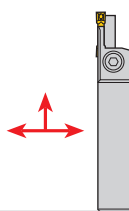
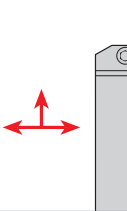
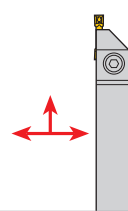
Axial Einstechen und Stechdrehen Face grooving and groove-turning					
Werkzeug Tool	CGACR/L...F.	CGACR/L...F.	CGFCR/L...F.	CGFCR..F..D..	CGFCR/L...F.
Anstellwinkel Setting angle	90°	90°	0°	0°	0°
Schnitttrichtung Cutting direction					
Seite Page	42	44	41	40	43
Wendeplatten Indexable inserts	FD LC... ED LC...	FD LC... ED LC...	FD LC... ED LC...	FD LC... ED LC...	FD LC... ED LC...
Seiten Pages	18-29	18-29	18-29	18-29	18-29

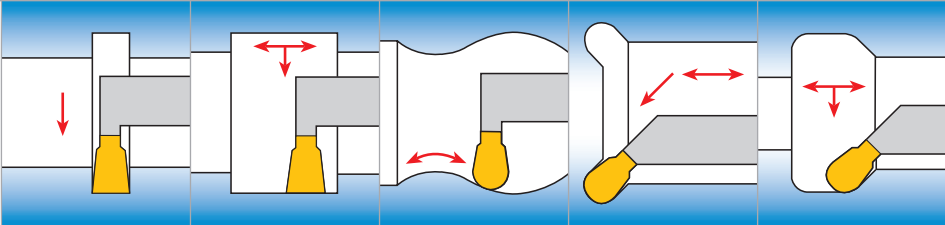
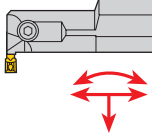
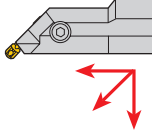
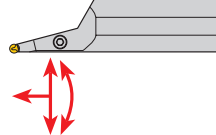
Innen Einstechen, Stechdrehen, Formdrehen und Freistechen Internal grooving, groove-turning, profiling and undercutting					
Werkzeug Tool	A..CGACR/L...I	S..CGSCR/L...I	S..CGKCR/L...I		
Anstellwinkel Setting angle	90°	45°	15°		
Schnitttrichtung Cutting direction					
Seite Page	45	46	48		
Wendeplatten Indexable inserts	ID LC... ID RC... ED RC...	ID RC... ED RC...	ED RC...		
Seiten Pages	18-29	18-29	29		

Spanformstufen zum Ein- und Abstechen
Geometries for parting and grooving

- GM (Grooving Medium),
- GF (Grooving Fine)
- UM (Universal Medium)
- GM (Grooving Medium),
- GF (Grooving Fine)
- UM (Universal Medium)

Kontrollierte Spanformung über einen breiten Anwendungsbereich.
Controlled chip forming over a wide range of application.

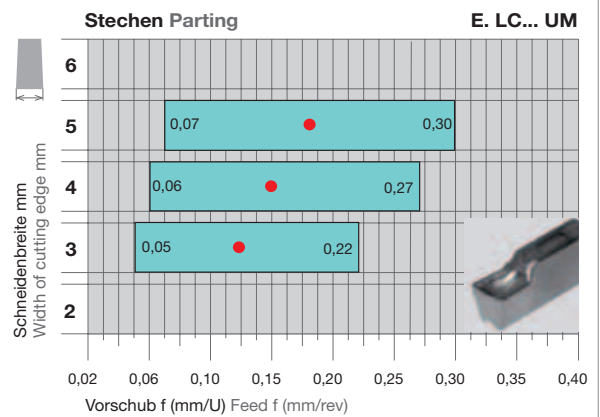
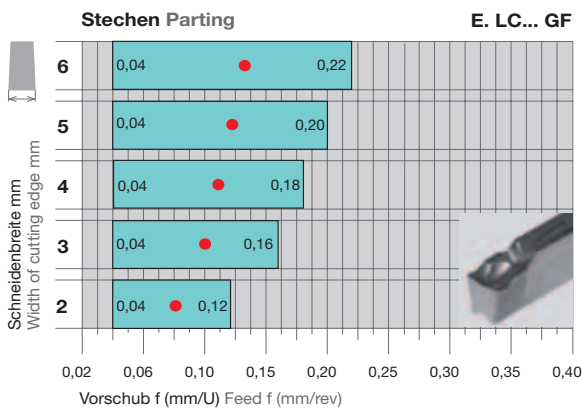
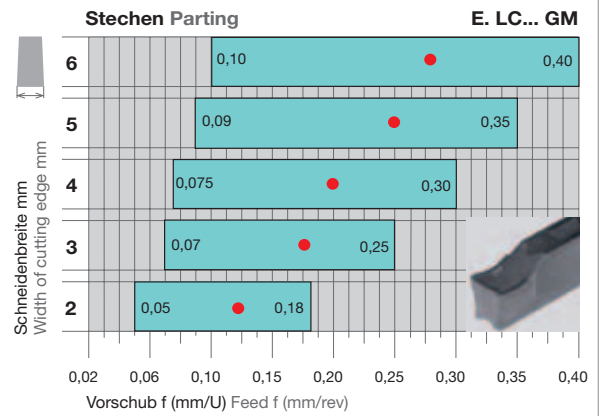

Spanformstufe zum Stechen und Stechdrehen
Geometries for grooving and groove turning

- TM (Turning Medium),
- RU (Round Universal)
- TM (Turning Medium),
- RU (Round Universal)

Kontrollierte Spanformung über einen breiten Anwendungsbereich.
Controlled chip forming over a wide range of application.

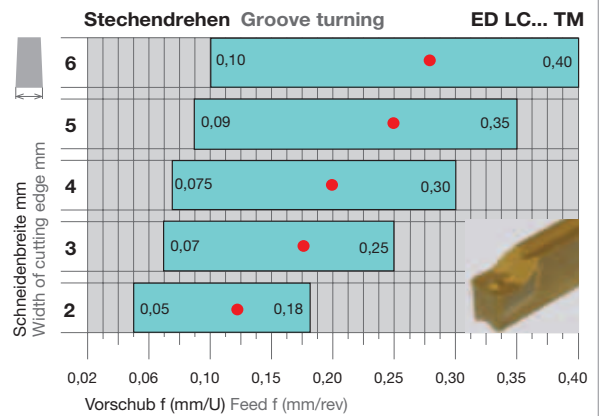

● Startwert
● Starting value

Spanformstufe zum Kopierdrehen von Aluminium
Geometries for copying aluminium

- TA (Turning Aluminium),
- TA (Turning Aluminium),

Kontrollierte Spanformung über einen breiten Anwendungsbereich.
Controlled chip forming over a wide range of application.

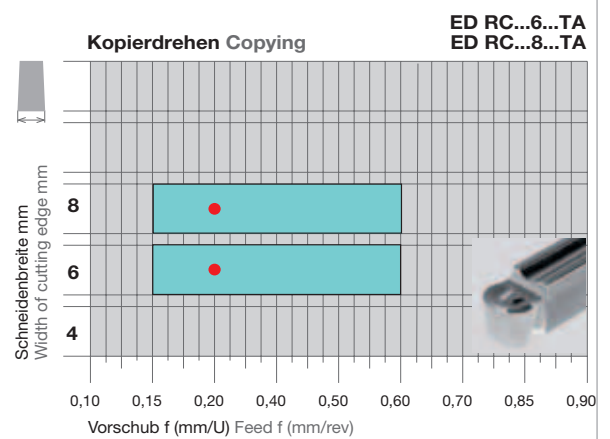





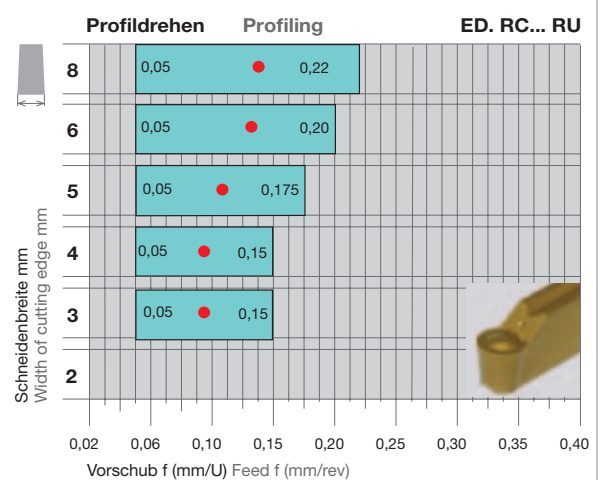
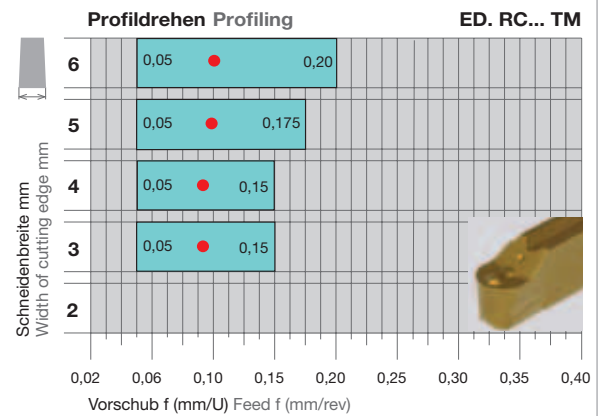

Spanformstufe zum Profildrehen
Geometries for profiling



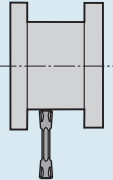
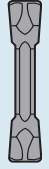

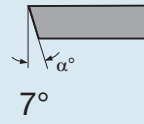

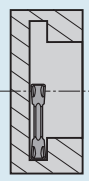
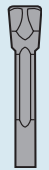
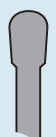

- TM (Turning Medium),
- TM (Turning Medium),

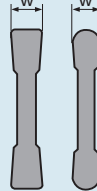

Kontrollierte Spanformung über einen breiten Anwendungsbereich.
Controlled chip forming over a wide range of application.



- Startwert
- Starting value

E Bearbeitungsart Type of machining	D Schneidenanzahl Number of cutting edges	L Wendepplattenform Indexable insert shape	C Freiwinkel Clearance angle	G Toleranzklasse Tolerance class
E  Außen External	D  Zwei Two	L  Gerade Straight	C  7°	G  +/- 0,025 mm
I  Innen Internal	S  Eine One	R  Rund Round		M  +/- 0,1 mm
F  Axial Axial				

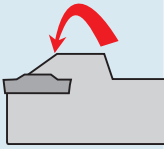
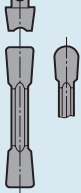
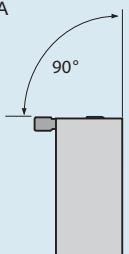
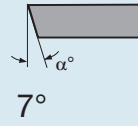
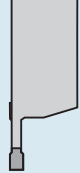
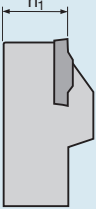
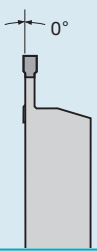
<p>R Plattentype Type of insert</p>	<p>3.00 - Stechbreite mm Grooving width mm</p>	<p>0.4 Eckenradius mm Corner radius mm</p>	<p>N Schnittrichtung Cutting direction</p>	<p>O Anstellwinkel κ° Approach angle κ°</p>
<p>N</p>  <p>Ohne Spanformrinne Without chip-former groove</p>			<p>L</p> <p>E. LC...:</p> 	
<p>R</p>  <p>Mit Spanformrinne With chip-former groove</p>			<p>w = 1,00 w = 1,30 w = 1,60 w = 1,85 w = 2,00 w = 2,15 w = 2,65 w = 3,00 w = 3,15 w = 4,00 w = 4,15 w = 4,78 w = 5,00 w = 5,15 w = 6,00 w = 8,00</p>	<p>r = 0,00 r = 0,10 r = 0,15 r = 0,20 r = 0,30 r = 0,40 r = 0,55 r = 0,80 r = 1,20 r = 1,50 r = 2,00 r = 2,39 r = 2,50 r = 3,00 r = 4,00</p>
			<p>N</p> <p>E. LC...:</p>  <p>Neutral Neutral</p>	
			<p>R</p> <p>E. LC...:</p>  <p>F. LC...:</p>  <p>Rechts Right hand</p>	

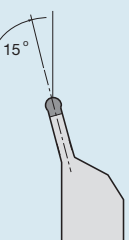
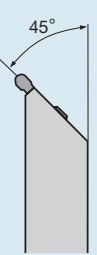
C Befestigungsarten Type of fixation	G Wendeplattentyp Type of insert	F Klemhalterform Shape of tool holder	C Freiwinkel Clearance angle	R Schnittrichtung Direction of cut	20 Schneidehöhe mm Height of cutting edge mm
<p>C</p>  <p>Von oben geklemmt Fixation from above</p>	<p>G</p>  <p>Stechplatte Grooving insert</p>	<p>A</p>  <p>90°</p>	<p>C</p>  <p>α° 7°</p>	<p>L</p>  <p>Links Left hand</p>	 <p>h_1</p>
		<p>F</p>  <p>0°</p>		<p>R</p>  <p>Rechts Right hand</p>	
		<p>K</p>  <p>15°</p>			
		<p>S</p>  <p>45°</p>			

20
Schaftbreite mm
Width of shank mm

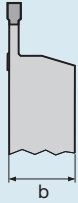

K
Werkzeuiglänge
Length of tool

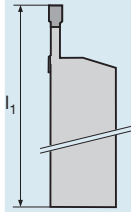

	l_1 mm
A	32 mm
B	40 mm
C	50 mm
D	60 mm
E	70 mm
F	80 mm
G	90 mm
H	100 mm
J	110 mm
K	125 mm
M	150 mm
N	160 mm
P	170 mm
Q	180 mm
R	200 mm
S	250 mm
T	300 mm
U	350 mm
V	400 mm
W	450 mm
Y	500 mm
X	Sonderlänge Other length

2
Wendepfattendicke
Size of insert

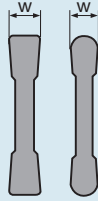

w
mm
2
3
4
5
6
8

E
Bearbeitungsart
Type of work

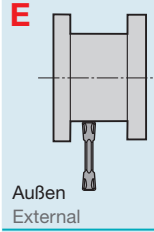

Außen
External

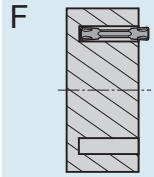

Axial
Axial

12.0
Stechtiefe mm
Depth of groove mm

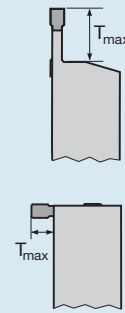

D50
Kleinsten Außendurchmesser mm
Minimum external diameter mm

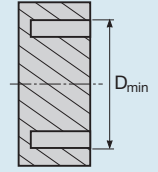

A
Haltertyp
Type of bar

A
Stahlschaft, mit innerer Kühlmittelzufuhr.
Steel shank, with internal coolant supply.

S
Stahlschaft, ohne besondere Konstruktionsmerkmale.
Steel shank with no special construction characteristics.

20
Stangendurchmesser
Diameter of shank

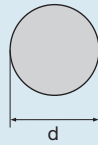

d
20
25
32
40

N
Werkzeuglänge
Length of tool

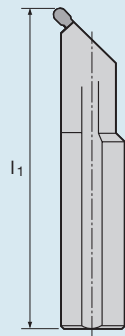

l₁ mm

A	32 mm
B	40 mm
C	50 mm
D	60 mm
E	70 mm
F	80 mm
G	90 mm
H	100 mm
J	110 mm
K	125 mm
M	150 mm
N	160 mm
P	170 mm
Q	180 mm
R	200 mm
S	250 mm
T	300 mm
U	350 mm
V	400 mm
W	450 mm
Y	500 mm
X	Sonderlänge Other length

C
Befestigungsart
Type of clamping

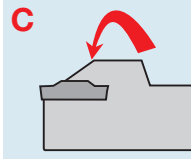

Von oben geklemmt
Fixation from above

G
Wendeplattentyp
Insert type

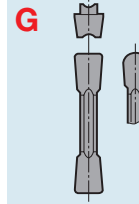



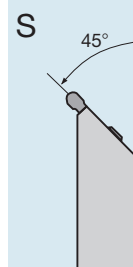
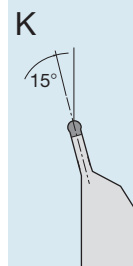
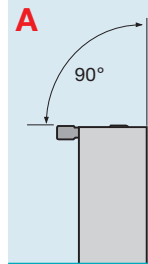

Stechplatte
Grooving insert

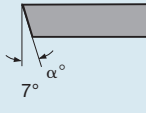
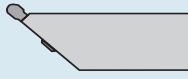
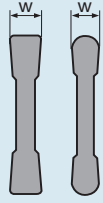
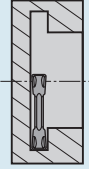
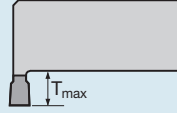
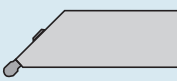
A
Klemmhalterform
Shape of tool holder

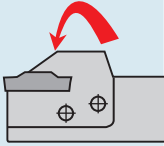
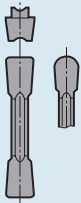
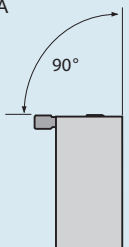
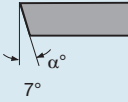

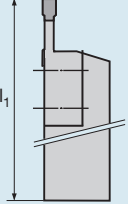
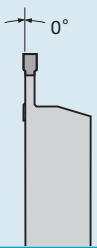
<p>C Freiwinkel Clearance angle</p>	<p>R Schnittrichtung Direction of cut</p>	<p>2 Wendepfannengröße Size of insert</p>	<p>I Bearbeitungsart Type of work</p>	<p>6.5 Stechtiefe mm Depth of groove mm</p>
<p>C</p> 	<p>L</p>  <p>Links Left hand</p>		<p>I</p>  <p>Innen Internal</p>	
	<p>R</p>  <p>Rechts Right hand</p>	<p>w mm 2 3 4 5 6 8</p>		

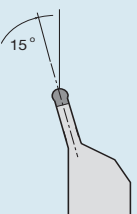
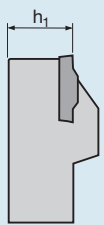
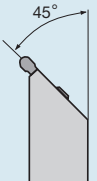
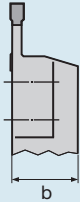
<p>X Befestigungsarten Type of fixation</p>	<p>G Wendeplattentyp Type of insert</p>	<p>F Klemmhalterform Shape of tool holder</p>	<p>C Freiwinkel Clearance angle</p>	<p>R Schnitttrichtung Direction of cut</p>	<p>K Werkzeuglänge Length of tool</p>																																														
<p>X</p>  <p>Seitlich geklemmt Clamped on the side</p>	<p>G</p>  <p>Stechplatte Grooving insert</p>	<p>A</p>  <p>90°</p>	<p>C</p>  <p>α° 7°</p>	<p>L</p>  <p>Links Left hand</p>	 <p>l_1</p>																																														
		<p>F</p>  <p>0°</p>		<p>R</p>  <p>Rechts Right hand</p>	<table border="1"> <thead> <tr> <th colspan="2">l_1 mm</th> </tr> </thead> <tbody> <tr><td>A</td><td>32 mm</td></tr> <tr><td>B</td><td>40 mm</td></tr> <tr><td>C</td><td>50 mm</td></tr> <tr><td>D</td><td>60 mm</td></tr> <tr><td>E</td><td>70 mm</td></tr> <tr><td>F</td><td>80 mm</td></tr> <tr><td>G</td><td>90 mm</td></tr> <tr><td>H</td><td>100 mm</td></tr> <tr><td>J</td><td>110 mm</td></tr> <tr><td>K</td><td>125 mm</td></tr> <tr><td>M</td><td>150 mm</td></tr> <tr><td>N</td><td>160 mm</td></tr> <tr><td>P</td><td>170 mm</td></tr> <tr><td>Q</td><td>180 mm</td></tr> <tr><td>R</td><td>200 mm</td></tr> <tr><td>S</td><td>250 mm</td></tr> <tr><td>T</td><td>300 mm</td></tr> <tr><td>U</td><td>350 mm</td></tr> <tr><td>V</td><td>400 mm</td></tr> <tr><td>W</td><td>450 mm</td></tr> <tr><td>Y</td><td>500 mm</td></tr> <tr><td>X</td><td>Sonderlänge Other length</td></tr> </tbody> </table>	l_1 mm		A	32 mm	B	40 mm	C	50 mm	D	60 mm	E	70 mm	F	80 mm	G	90 mm	H	100 mm	J	110 mm	K	125 mm	M	150 mm	N	160 mm	P	170 mm	Q	180 mm	R	200 mm	S	250 mm	T	300 mm	U	350 mm	V	400 mm	W	450 mm	Y	500 mm	X	Sonderlänge Other length
l_1 mm																																																			
A	32 mm																																																		
B	40 mm																																																		
C	50 mm																																																		
D	60 mm																																																		
E	70 mm																																																		
F	80 mm																																																		
G	90 mm																																																		
H	100 mm																																																		
J	110 mm																																																		
K	125 mm																																																		
M	150 mm																																																		
N	160 mm																																																		
P	170 mm																																																		
Q	180 mm																																																		
R	200 mm																																																		
S	250 mm																																																		
T	300 mm																																																		
U	350 mm																																																		
V	400 mm																																																		
W	450 mm																																																		
Y	500 mm																																																		
X	Sonderlänge Other length																																																		
		<p>K</p>  <p>15°</p>		<p>20 Schneidehöhe mm Height of cutting edge mm</p>  <p>h_1</p>																																															
		<p>S</p>  <p>45°</p>		<p>20 Schaftbreite mm Width of shank mm</p>  <p>b</p>																																															

X
Befestigungsarten
Type of fixation

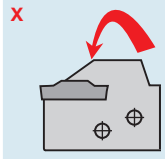

Seitlich geklemmt
Colateral fixation

G
Wendeplattentyp
Type of insert

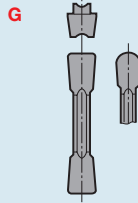

Stechplatte
Grooving insert

F
Klemmhalterform
Shape of tool holder

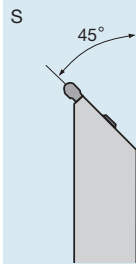
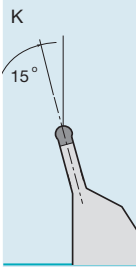
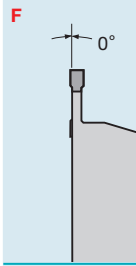
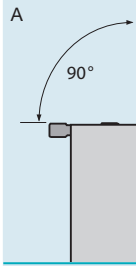

C
Freiwinkel
Clearance angle

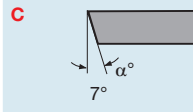

R
Schnittrichtung
Direction of cut

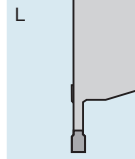

Links
Left hand

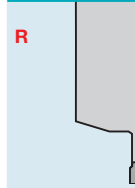

Rechts
Right hand

2
Wendeplattengröße
Size of insert

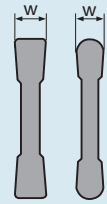



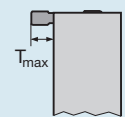
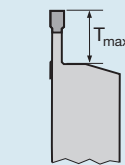

w
mm
2
3
4
5
6
8

F20
Stechtiefe mm
Depth of groove mm

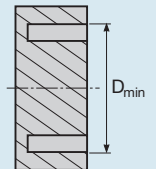

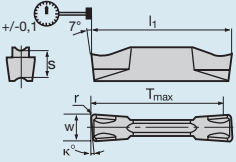
D55
Kleinster Aussendurchmesser mm
Minimum external diameter mm



	Bestellbezeichnung Ordering code	w +/- 0,05	r	κ	l ₁	s	T _{max}	HM-Sorte Grade					
								LC232F	LC242W	LC432T	LC442W	LW612	
ED LCMR...N0 GM 	ED LCMR 2.00-0.2N0 GM	2,0	0,20	0°	20	4,7	19		●	●	●	●	
	ED LCMR 3.00-0.2N0 GM	3,0	0,20	0°	20	4,7	19		●	●	●	●	
	ED LCMR 4.00-0.3N0 GM	4,0	0,30	0°	20	4,7	19		●	●	●	●	
	ED LCMR 5.00-0.3N0 GM	5,0	0,30	0°	25	5,2	24		●	●	●	●	
	ED LCMR 6.00-0.3N0 GM	6,0	0,30	0°	25	5,2	24		●	●	●	●	
	ED LCMR 8.00-0.4N0 GM	8,0	0,40	0°	30	6,4	29			○	○		
ED LCMR...L...GM 	ED LCMR 2.00-0.2L6 GM	2,0	0,20	6°	20	4,7	19		●	●	●	●	
	ED LCMR 3.00-0.2L6 GM	3,0	0,20	6°	20	4,7	19		●	●	●	●	
	ED LCMR 4.00-0.3L4 GM	4,0	0,30	4°	20	4,7	19		●	●	●	●	
	ED LCMR 5.00-0.3L4 GM	5,0	0,30	4°	25	5,2	24		●		●	●	
	ED LCMR 3.00-0.2L15 GM	3,0	0,20	15°	20	4,7	19			○	○		
	ED LCMR 4.00-0.3L15 GM	4,0	0,30	15°	20	4,7	19				○		
ED LCMR...R...GM 	ED LCMR 2.00-0.2R6 GM	2,0	0,20	6°	20	4,7	19		●	●	●	●	
	ED LCMR 3.00-0.2R6 GM	3,0	0,20	6°	20	4,7	19		●	●	●	●	
	ED LCMR 4.00-0.3R4 GM	4,0	0,30	4°	20	4,7	19		●	●	●	●	
	ED LCMR 5.00-0.3R4 GM	5,0	0,30	4°	25	5,2	24		●	●	●	●	
	ED LCMR 3.00-0.2R15 GM	3,0	0,20	15°	20	4,7	19		●		●		
ED LCMR...N0 UM 	ED LCMR 3.00-0.3N0 UM	3,0	0,30	0°	20	4,7	19		○	○			
	ED LCMR 4.00-0.4N0 UM	4,0	0,40	0°	20	4,7	19		○	○			
	ED LCMR 5.00-0.4N0 UM	5,0	0,50	0°	25	5,2	24		○	○			

Passende Werkzeuge
 Suitable holders



Seite Page 32

Seite Page 34

Seite Page 36

Seite Page 37

Seite Page 38





Seite Page 40

Seite Page 50

Bestellbeispiel Order example: 10 Stück off ED LCMR 2.00-0.2N0 GM LC242W

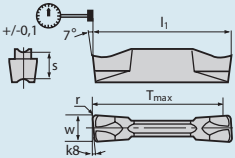
- Verfügbar ab Lager Available from stock
- Auf Anfrage On request

Schnittdatenrichtwerte siehe Seite 62 – 71
 For cutting data standard values see pages 62 – 71

	Bestellbezeichnung Ordering code	w +/- 0,05	r	κ	l ₁	s	T _{max}	HM-Sorte Grade					
								LC232F	LC242W	LC432T	LC442W	LW612	
ED LCMR...N0 GF 	ED LCMR 1.40-0.16N0 GF	1,4	0,16	0°	16	4,0	15			●	●		
	ED LCMR 2.00-0.2N0 GF	2,0	0,20	0°	20	4,7	19		●	●	●	●	
	ED LCMR 3.00-0.2N0 GF	3,0	0,20	0°	20	4,7	19		●	●	●	●	
	ED LCMR 4.00-0.3N0 GF	4,0	0,30	0°	20	4,7	19		●	●	●	●	
	ED LCMR 5.00-0.3N0 GF	5,0	0,30	0°	25	5,2	24		●	●	●	●	
	ED LCMR 6.00-0.3N0 GF	6,0	0,30	0°	25	5,2	24		●	●	●	●	
ED LCMR...L...GF 	ED LCMR 2.00-0.2L6 GF	2,0	0,20	6°	20	4,7	19		●	●	●	●	
	ED LCMR 2.00-0.2L15 GF	2,0	0,20	15°	20	4,7	19		●	●	●		
	ED LCMR 3.00-0.2L6 GF	3,0	0,20	6°	20	4,7	19		●	●	●	●	
	ED LCMR 3.00-0.2L15 GF	3,0	0,20	15°	20	4,7	19		●	●	●		
	ED LCMR 4.00-0.3L4 GF	4,0	0,30	4°	20	4,7	19		●		●	●	
	ED LCMR 4.00-0.3L15 GF	4,0	0,30	15°	20	4,7	19		●				
	ED LCMR 5.00-0.3L4 GF	5,0	0,30	4°	25	5,2	24		●		●	●	
ED LCMR...R...GF 	ED LCMR 2.00-0.2R6 GF	2,0	0,20	6°	20	4,7	19		●	●	●	●	
	ED LCMR 2.00-0.2R15 GF	2,0	0,20	15°	20	4,7	19		●	●	●		
	ED LCMR 3.00-0.2R6 GF	3,0	0,20	6°	20	4,7	19		●	●	●	●	
	ED LCMR 3.00-0.2R15 GF	3,0	0,20	15°	20	4,7	19		●	●	●		
	ED LCMR 4.00-0.3R4 GF	4,0	0,30	4°	20	4,7	19		●		●	●	
	ED LCMR 4.00-0.3R15 GF	4,0	0,30	15°	20	4,7	19		○		○		
	ED LCMR 5.00-0.3R4 GF	5,0	0,30	4°	25	5,2	24		●		●	○	

Passende Werkzeuge
Suitable holders



Seite Page 32

Seite Page 34

Seite Page 36

Seite Page 37

Seite Page 38





Seite Page 40

Seite Page 50

Bestellbeispiel Order example: 10 Stück off ED LCMR 1.40-0.16N0 GF LC442W

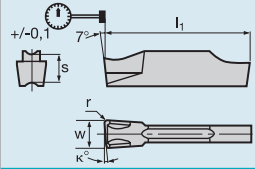
- Verfügbar ab Lager Available from stock
- Auf Anfrage On request

Schnittdatenrichtwerte siehe Seite 62 – 71
 For cutting data standard values see pages 62 – 71

	Bestellbezeichnung Ordering code	w +/- 0,05	r	κ	l ₁	s	T _{max}	HM-Sorte Grade					
		LC232F	LC242W	LC432T	LC442W	LW612							
ES LCMR...N0 GM 	ES LCMR 2.00-0.2N0 GM	2,0	0,20	0°	20	4,7		●	●	●	●		
	ES LCMR 3.00-0.2N0 GM	3,0	0,20	0°	20	4,7		●	●	●	●		
	ES LCMR 4.00-0.3N0 GM	4,0	0,30	0°	20	4,7		●	●	●	●		
	ES LCMR 5.00-0.3N0 GM	5,0	0,30	0°	25	5,2		●	●	●	●		
	ES LCMR 6.00-0.3N0 GM	6,0	0,30	0°	25	5,2		●	●	●	●		
ES LCMR...L...GM 	ES LCMR 2.00-0.2L6 GM	2,0	0,20	6°	20	4,7		●		●	●		
	ES LCMR 3.00-0.2L6 GM	3,0	0,20	6°	20	4,7		●		●	●		
	ES LCMR 4.00-0.3L4 GM	4,0	0,30	4°	20	4,7		●		●	●		
ES LCMR...R...GM 	ES LCMR 2.00-0.2R6 GM	2,0	0,20	6°	20	4,7		●	●	●	●		
	ES LCMR 3.00-0.2R6 GM	3,0	0,20	6°	20	4,7		●	●	●	●		
	ES LCMR 4.00-0.3R4 GM	4,0	0,30	4°	20	4,7		●	●	●	●		

Passende Werkzeuge
 Suitable holders

						
PB...	PBT...	CGFC...E...D	XGFC...			

Seite Page 32

Seite Page 34

Seite Page 36





Seite Page 50

Bestellbeispiel Order example: 10 Stück off ES LCMR 2.00-0.2N0 GM LC242W

- Verfügbar ab Lager Available from stock
- Auf Anfrage On request

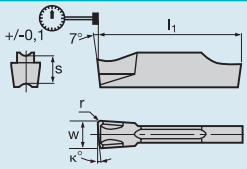
Schnittdatenrichtwerte siehe Seite 62 – 71

For cutting data standard values see pages 62 – 71

	Bestellbezeichnung Ordering code	w +/- 0,05	r	kappa	I ₁	s	T _{max}	HM-Sorte Grade				
								LC232F	LC242W	LC432T	LC442W	LW612
ES LCMR...N0 GF 	ES LCMR 2.00-0.2N0 GF	2,0	0,20	0°	20	4,7		●	●	●		
	ES LCMR 3.00-0.2N0 GF	3,0	0,20	0°	20	4,7		●	●	●	●	
	ES LCMR 4.00-0.3N0 GF	4,0	0,30	0°	20	4,7		●	●	●	●	
	ES LCMR 5.00-0.3N0 GF	5,0	0,30	0°	25	5,2		●		●	●	
	ES LCMR 6.00-0.3N0 GF	6,0	0,30	0°	25	5,2		●		●	●	
ES LCMR...L...GF 	ES LCMR 2.00-0.2L6 GF	2,0	0,20	6°	20	4,7		●		●	●	
	ES LCMR 2.00-0.2L15 GF	2,0	0,20	15°	20	4,7		●		●		
	ES LCMR 3.00-0.2L6 GF	3,0	0,20	6°	20	4,7		●	●	●	●	
	ES LCMR 3.00-0.2L15 GF	3,0	0,20	15°	20	4,7		●		●		
	ES LCMR 4.00-0.3L4 GF	4,0	0,30	4°	20	4,7		●		●	●	
	ES LCMR 4.00-0.3L15 GF	4,0	0,30	15°	20	4,7		●		●		
ES LCMR...R...GF 	ES LCMR 2.00-0.2R6 GF	2,0	0,20	6°	20	4,7		●	●	●		
	ES LCMR 2.00-0.2R15 GF	2,0	0,20	15°	20	4,7		○		○		
	ES LCMR 3.00-0.2R6 GF	3,0	0,20	6°	20	4,7		●	●	●	●	
	ES LCMR 3.00-0.2R15 GF	3,0	0,20	15°	20	4,7		●		●		
	ES LCMR 4.00-0.3R4 GF	4,0	0,30	4°	20	4,7		●		●	●	
	ES LCMR 4.00-0.3R15 GF	4,0	0,30	15°	20	4,7		○				

Passende Werkzeuge

Suitable holders

						
PB...	PBT...	CGFC...E...D	XGFC...			

Seite Page 32

Seite Page 34

Seite Page 36

Seite Page 50

Bestellbeispiel Order example: 10 Stück off ES LCMR 2.00-0.2N0 GF LC242W

- Verfügbar ab Lager Available from stock
- Auf Anfrage On request

Schnittdatenrichtwerte siehe Seite 62 – 71
 For cutting data standard values see pages 62 – 71

									HM-Sorte Grade						
		w +/- 0,02	r +/- 0,03	b	l ₁	s	T _{max}	LC232F	LC242W	LC432T	LC442W	LW612			
ED LCGR...TM 	Bestellbezeichnung Ordering code														
	ED LCGR 1.00-0.0 TM	1,00	0,00	2,2	20	4,7	2		●	●			●		
	ED LCGR 1.30-0.0 TM	1,30	0,00	2,2	20	4,7	2		●	●			●		
	ED LCGR 1.60-0.1 TM	1,60	0,10	2,2	20	4,7	2		●	●			●		
	ED LCGR 1.85-0.1 TM	1,85	0,10	2,2	20	4,7	3		●	●			●		
	ED LCGR 2.15-0.1 TM	2,15	0,15	2,2	20	4,7	3		●				●		
	ED LCGR 2.65-0.1 TM	2,65	0,15	2,2	20	4,7	5		●				●		
	ED LCGR 3.15-0.1 TM	3,15	0,15	2,2	20	4,7	5		●				●		
	ED LCGR 4.15-0.1 TM	4,15	0,15	3,0	20	4,7	5						●		
ED LCGR 5.15-0.1 TM	5,15	0,15	4,0	25	5,2	5		●				●			
ID LCGR...TM 	ID LCGR 1.30-0.0 TM	1,30	0,00	2,2	20	4,7	2	●					●		
	ID LCGR 1.60-0.1 TM	1,60	0,10	2,2	20	4,7	2	●					●		
	ID LCGR 1.85-0.1 TM	1,85	0,10	2,2	20	4,7	3	●					●		
	ID LCGR 2.15-0.1 TM	2,15	0,15	2,2	20	4,7	3	●					●		

Passende Werkzeuge
 Suitable holders



Seite Page 37

Seite Page 38

Seite Page 40

Seite Page 43

Seite Page 44





Seite Page 45

Seite Page 50

Bestellbeispiel Order example: 10 Stück off ED LCGR 1.00-0.0 TM LC242W

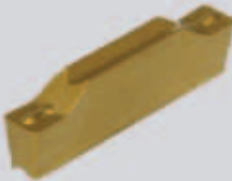
- Verfügbar ab Lager Available from stock
- Auf Anfrage On request

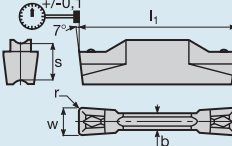
Schnittdatenrichtwerte siehe Seiten 62 – 71
 For cutting data standard values see pages 62 – 71

														
					HM-Sorte Grade									
ED LCMR... TM 	Bestellbezeichnung Ordering code	w +/- 0,05	r b l₁ s T_{max}	<table border="1"> <tr> <td style="background-color: #4F81BD; color: white;">LC232F</td> <td style="background-color: #FFD700;">LC242W</td> <td style="background-color: #FFD700;">LC432T</td> <td style="background-color: #FFD700;">LC442W</td> <td style="background-color: #FF0000; color: white;">LW612</td> </tr> <tr> <td style="text-align: center;">●</td> <td style="text-align: center;">●</td> <td style="text-align: center;">●</td> <td style="text-align: center;">●</td> <td style="text-align: center;">●</td> </tr> </table>	LC232F	LC242W	LC432T	LC442W	LW612	●	●	●	●	●
LC232F	LC242W	LC432T	LC442W	LW612										
●	●	●	●	●										
	ED LCMR 3.00-0.4 TM ED LCMR 4.00-0.4 TM	3,0 4,0	0,40 2,2 20 4,7 0,40 3,0 20 4,7											

Passende Werkzeuge
 Suitable holders





Seite Page 37 Seite Page 38 Seite Page 40 Seite Page 41 Seite Page 50

Bestellbeispiel Order example: 10 Stück off ED LCMR 3.00-0.4 TM LC242W

- Verfügbar ab Lager Available from stock
- Auf Anfrage On request

Schnittdatenrichtwerte siehe Seiten 62 – 71
 For cutting data standard values see pages 62 – 71

	Bestellbezeichnung Ordering code	w +/- 0,02	w +/- 0,05	b	l ₁	s	T _{max}	HM-Sorte Grade						
								LC232F	LC242W	LC432T	LC442W	LW612		
	ED LCGR 3.00-0.2 TM	3,0	0,20	2,2	20	4,7		●	●	○				
	ED LCGR 3.00-0.4 TM	3,0	0,40	2,2	20	4,7		●	●	○				
	ED LCGR 4.00-0.4 TM	4,0	0,40	3,0	20	4,7		●	●	○				
	ED LCGR 4.00-0.8 TM	4,0	0,80	3,0	20	4,7		●	●	○				
	ED LCGR 5.00-0.4 TM	5,0	0,40	4,0	25	5,2		●	●	○				
	ED LCGR 5.00-0.8 TM	5,0	0,80	4,0	25	5,2		●	●	○				
	ED LCGR 6.00-0.8 TM	6,0	0,80	5,0	25	5,2		●	●	○				
	ED LCGR 6.00-1.2 TM	6,0	1,20	5,0	25	5,2		●	●	○				
	ED LCGR 8.00-0.8 TM	8,0	0,80	6,0	30	6,4		●	●	○				
ED LCGR 8.00-1.2 TM	8,0	1,20	6,0	30	6,4		●	●	○					

Passende Werkzeuge

Suitable holders



Seite Page 37

Seite Page 38

Seite Page 40

Seite Page 43



Seite Page 50

Bestellbeispiel Order example: 10 Stück off ED LCGR 3.00-0.4 TM LC242W

- Verfügbar ab Lager Available from stock
- Auf Anfrage On request

Schnittdatenrichtwerte siehe Seiten 62 – 71

For cutting data standard values see pages 62 – 71

									HM-Sorte Grade				
		w +/- 0,02	r +/- 0,05	b	l ₁	s	T _{max}		LC232F	LC242W	LC432T	LC442W	LW612
ED RCGR...TM 	ED RCGR 3.00 TM	3,0	1,50	2,2	20	4,7			●	●		○	
	ED RCGR 4.00 TM	4,0	2,00	3,0	20	4,7			●	●		○	
	ED RCGR 5.00 TM	5,0	2,50	4,0	25	5,2			●	●		○	
	ED RCGR 6.00 TM	6,0	3,00	5,0	25	5,2			●	●		○	
ED RCMR...RU 	ED RCMR 3.00 RU	3,0	1,50	2,2	20	4,7					○		
	ED RCMR 5.00 RU	5,0	2,50	4,0	25	5,2					○		
	ED RCMR 6.00 RU	6,0	3,00	5,0	25	5,2					○		
	ED RCMR 8.00 RU	8,0	4,00	6,0	30	6,4					○		

Passende Werkzeuge
 Suitable holders



Seite Page 38

Seite Page 40

Seite Page 39





Seite Page 43

Seite Page 50

Bestellbeispiel Order example: 10 Stück off ED RCGR 3.00 TM LC242W

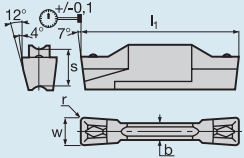
- Verfügbar ab Lager Available from stock
- Auf Anfrage On request

Schnittdatenrichtwerte siehe Seiten 62 – 71
 For cutting data standard values see pages 62 – 71

	Bestellbezeichnung Ordering code	w +/- 0,05	r	b	l ₁	s	T _{max}	HM-Sorte Grade				
								LC232F	LC242W	LC432T	LC442W	LW612
FD LCMR...L TM  	FD LCMR 3.00-0.4L TM	3,0	0,40	2,2	20	4,7		●			●	
	FD LCMR 4.00-0.4L TM	4,0	0,40	3,0	20	4,7		●			●	
FD LCMR...R TM  	FD LCMR 3.00-0.4R TM	3,0	0,40	2,2	20	4,7		●			●	
	FD LCMR 4.00-0.4R TM	4,0	0,40	3,0	20	4,7		●			●	

Passende Werkzeuge
 Suitable holders



Seite Page 40

Seite Page 41

Seite Page 42

Seite Page 43



Seite Page 44

Seite Page 50

Bestellbeispiel Order example: 10 Stück off FD LCMR 3.00-0.4L TM LC242W

- Verfügbar ab Lager Available from stock
- Auf Anfrage On request

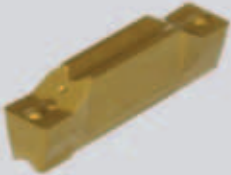
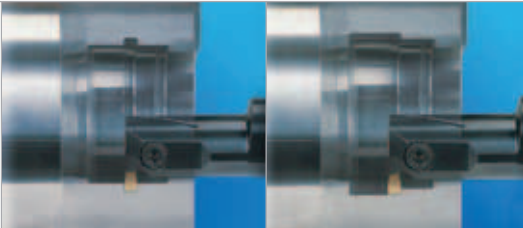
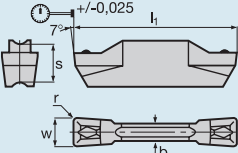
Schnittdatenrichtwerte siehe Seiten 62 – 71
 For cutting data standard values see pages 62 – 71

																			
	Bestellbezeichnung Ordering code	w +/- 0,02	r +/- 0,05	b	l₁	s	T_{max}	HM-Sorte Grade											
ID LCGR...TM 	ID LCGR 3.00-0.4 TM	3,0	0,40	2,2	20	4,7													
	ID LCGR 4.00-0.4 TM	4,0	0,40	3,0	20	4,7													
	ID LCGR 4.00-0.8 TM	4,0	0,80	3,0	20	4,7													
	ID LCGR 5.00-0.4 TM	5,0	0,40	4,0	25	5,2													
	ID LCGR 5.00-0.8 TM	5,0	0,80	4,0	25	5,2													
	ID LCGR 6.00-0.8 TM	6,0	0,80	5,0	25	5,2													
	ID LCGR 6.00-1.2 TM	6,0	1,20	5,0	25	5,2													
	ID LCGR 8.00-0.8 TM	8,0	0,80	6,0	30	6,4													
	ID LCGR 8.00-1.2 TM	8,0	1,20	6,0	30	6,4													

Passende Werkzeuge
Suitable holders

																			
A...CGAC...I...																			

Seite Page 45

Bestellbeispiel Order example: 10 Stück off ID LCGR 3.00-0.4 TM LC242W

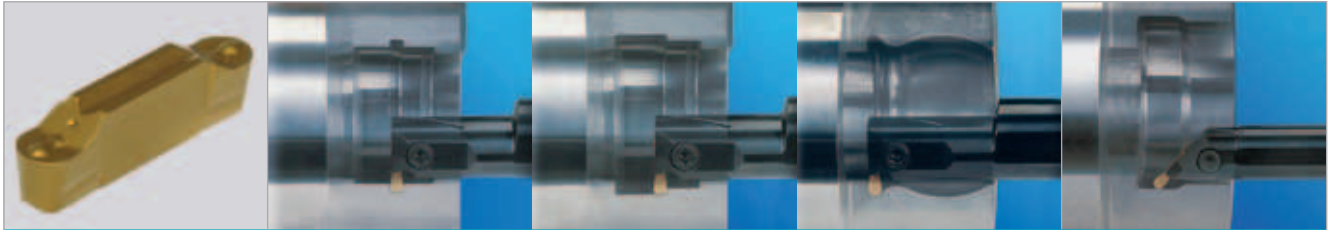

- Verfügbar ab Lager Available from stock
- Auf Anfrage On request

Schnittdatenrichtwerte siehe Seiten 62 – 71
 For cutting data standard values see pages 62 – 71



	Bestellbezeichnung Ordering code	w +/- 0,02	r +/- 0,05	b	l ₁	s	T _{max}	HM-Sorte Grade				
								LC232F	LC242W	LC432T	LC442W	LW612
ID RCGR...TM 	ID RCGR 3.00 TM	3,0	1,5	2,2	20	4,7			●			○
	ID RCGR 4.00 TM	4,0	2,0	3,0	20	4,7			●			○
	ID RCGR 5.00 TM	5,0	2,5	4,0	25	5,2			●			○
	ID RCGR 6.00 TM	6,0	3,0	5,0	25	5,2			●			





Passende Werkzeuge
 Suitable holders

							
A...CGAC...I...	S...CGSC...I...						

Seite Page 45 Seite Page 46
 Bestellbeispiel Order example: 10 Stück off ID RCGR 3.00 TM LC242W

- Verfügbar ab Lager Available from stock
- Auf Anfrage On request

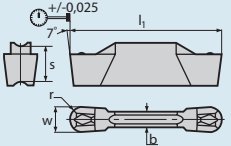
Schnittdatenrichtwerte siehe Seiten 62 – 71
 For cutting data standard values see pages 62 – 71

												
	Bestellbezeichnung Ordering code	w	r	b	l₁	s	T_{max}	HM-Sorte Grade				
		+/- 0,02	+/- 0,05						LC232F	LC242W	LC432T	LC442W
ED RCGR...TA 	ED RCGR 6.00 TA	6,0	3,0	5,0	25	5,2						●
	ED RCGR 8.00 TA	8,0	4,0	6,0	30	6,4						●

Passende Werkzeuge
 Suitable holders



Seite Page 37 Seite Page 39 Seite Page 45 Seite Page 46 Seite Page 47 Seite Page 48

Bestellbeispiel Order example: 10 Stück off ED RCGR 6.00 TA LW612

- Verfügbar ab Lager Available from stock
- Auf Anfrage On request

Schnittdatenrichtwerte siehe Seiten 62 – 71
 For cutting data standard values see pages 62 – 71



Häufig wiederkehrende Profile?
Hohe Genauigkeit der Profile?
Komplexe Profile?
 Frequently required profiles?
 High precision of the profiles?
 Difficult?

Ab 10 Stück:
 Profilwendeplatten nach Ihren Vorgaben.
 10 Pieces or more:
 Profile inserts according to your design.

Anfragen bitte mit nebenstehendem Blatt.
 Please use the form on the opposite page for your enquiry.

Übliche Toleranzen Usual tolerances	
Stechbreite Grooving width	+/- 0,02 mm
Radien und Fasen Radii and chamfers	+/- 0,05 mm
Winkel Angles	+/- 0,5°
Profiltiefe Profile depth	+ 0,1 mm
Innenradius Inside radius	mind. 0,1 mm

Absender Sender
Firma Company
Name Name
Abteilung Department
Straße Street
PLZ/Ort Town & Post Code
Tel.
Fax

Bearbeitung Machining	<input type="checkbox"/> Außen External	<input type="checkbox"/> Innen Internal	<input type="checkbox"/> Axial Axial
Werkstoff Material			
Kleinster Durchmesser Least diameter mm			

Handskizze des bemaßten Teileprofils/Maßstab 10 : 1
 Hand drawing of the part profile, measured/scale 10 : 1

Beispiel:
 Example:

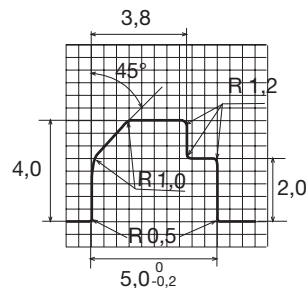
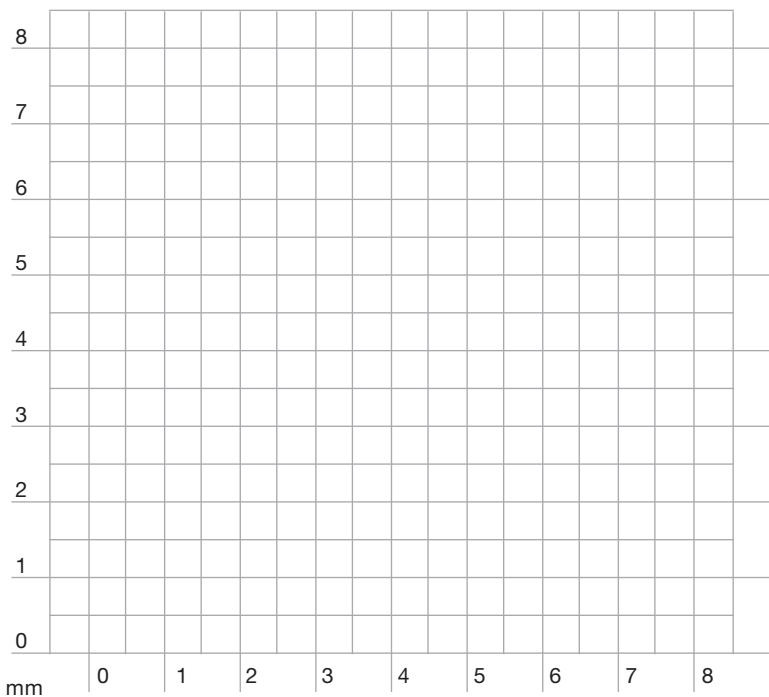

Seite einfach kopieren, ausfüllen und faxen
 Please copy this sheet, fill in and fax



PB (Klingen) PB (Parting blade)	Bestellbezeichnung Ordering code	h	l ₁	h ₁	b	w	D _{max.}	Schneideinsatz Insert	Spannblock Parting holder
PB 26-. 	PB 26-2	26	150	21,4	1,8 ¹⁾	2,0-2,2	39	ED LCMR...GM	PH..-26
	PB 26-3	26	150	21,4	2,4	2,4-3,3	70	ED LCMR...GF	
	PB 26-4	26	150	21,4	3,2	3,6-4,2	80	ES LCMR...GM ES LCMR...GF	
	PB 26-1,4 S³⁾	26	150	21,4	1,0	1,4	26	ED LCMR...GF	
PB 32-. 	PB 32-1,4	32	150	24,8	1,0	2,4	25	ED LCMR...GM	PH..-32
	PB 32-2	32	150	24,8	1,8 ¹⁾	1,9-2,5	40	ED LCMR...GF	
	PB 32-3	32	150	24,8	2,4	2,4-3,3	100	ES LCMR...GM	
	PB 32-4	32	150	24,8	3,2	3,2-4,3	100	ES LCMR...GF	
	PB 32-5	32	150	24,8	4,0	4,2-5,3	120	ED LCMR...GF	
	PB 32-6	32	150	24,8	5,2	5,2-6,3	120	ED LCMR...GM	
	PB 32-8	32	150	24,8	3,2	8	80	ED LCMR...UM	
PB 45-. 	PB 45-4	45	150	38,1	3,2	4	20	ED LCMR4...GM ED LCMR4...GF ES LCMR4...GM ES LCMR4...GF ED LCMR4...UM	PH..-45

Ersatzteile Spare parts	Bestellbezeichnung Ordering code		
 Schlüssel ²⁾ Key ²⁾			
	VO7-E1230		
	VO7-E1220	für PB 26-1.4S	

Passende Wendepplatten

Suitable inserts

ED LC...GM/GF	ES LC...GM/GF				

Seiten Pages
18, 19

Seiten Pages
20, 21

Bestellbeispiel Order example: 1 Stück off PB 26-2

- 1) Breite nur im Stechtiefenbereich, durchgängige Breite ist 2,4 mm
 1) Width only in grooving depth area, width of the body of the blade is 2,4 mm
- 2) Schlüssel ist nicht im Lieferumfang enthalten. Bei Bedarf bitte separat bestellen
 2) Key is not included in the delivery. If necessary, please order separate
- 3) Einseitig
 3) Single



PB (Klingen) PB (Parting blade)	Bestellbezeichnung Ordering code	h	l ₁	h ₁	b	w	d _{min}	T _{max.}	Schneideinsatz Insert	Spannblock Parting holder
PB 32-. 	PBFR-32-3T20-D40	32	150	24,8	5,2	3	40	20	ED LCMR...GM	PH...-32
	PBFL-32-3T20-D40	32	150	24,8	5,2	3	40	20	ED LCMR...GF	
	PBFR-32-3T20-D54	32	150	24,8	5,2	3	54	20	ES LCMR...GM	
	PBFL-32-3T20-D54	32	150	24,8	5,2	3	54	20	ES LCMR...GF	
	PBFR-32-3T25-D74	32	150	24,8	5,2	3	74	25	ED LCMR...GF	
	PBFL-32-3T25-D74	32	150	24,8	5,2	3	74	25	ED LCMR...UM	
	PBFR-32-3T25-D114	32	150	24,8	5,2	3	114	25		
	PBFL-32-3T25-D114	32	150	24,8	5,2	3	114	25		
	PBFR-32-4T25-D40	32	150	24,8	5,2	4	40	25		
	PBFL-32-4T25-D40	32	150	24,8	5,2	4	40	25		
	PBFR-32-4T25-D50	32	150	24,8	5,2	4	50	25		
	PBFL-32-4T25-D50	32	150	24,8	5,2	4	50	25		
	PBFR-32-4T30-D70	32	150	24,8	5,2	4	70	30		
	PBFL-32-4T30-D70	32	150	24,8	5,2	4	70	30		
	PBFR-32-4T30-D120	32	150	24,8	5,2	4	120	30		
	PBFL-32-4T30-D120	32	150	24,8	5,2	4	120	30		
	PBFR-32-5T32-D60	32	150	24,8	5,2	5	60	32		
	PBFL-32-5T32-D60	32	150	24,8	5,2	5	60	32		
	PBFR-32-5T35-D85	32	150	24,8	5,2	5	85	35		
	PBFL-32-5T35-D85	32	150	24,8	5,2	5	85	35		
	PBFR-32-5T35-D130	32	150	24,8	5,2	5	130	35		
	PBFL-32-5T35-D130	32	150	24,8	5,2	5	130	35		
	PBFR-32-6T32-D80	32	150	24,8	5,2	6	80	32		
	PBFL-32-6T32-D80	32	150	24,8	5,2	6	80	32		
PBFR-32-6T38-D168	32	150	24,8	5,2	6	168	38			
PBFL-32-6T38-D168	32	150	24,8	5,2	6	168	38			

Ersatzteile Spare parts	Bestellbezeichnung Ordering code
	
Schlüssel ⁽²⁾ Key ⁽²⁾	
	VO7-E1230

Passende Wendeplatten
Suitable inserts

ED LC...GM/GF	ES LC...GM/GF				
					

**Klingen für Traub Maschinen,
Außen Einstechen und Abstechen, große Tiefen**
Blades for Traub machines,
external grooving, greater depths

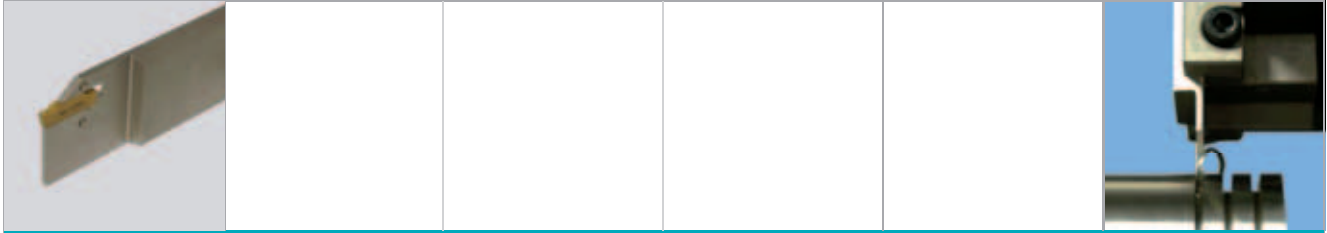

PB (Klingen) PB (Parting blade)	Bestellbezeichnung Ordering code	h	l ₁	h ₁	b	b ₁	w		Schneideinsatz Indexable insert	Spannblock Parting holder
PBT 	PBTR/L 32-2 D42	32	110	24,8	1,8	8	1,90-2,4	47	ED LCMR...GM	PH ..-32
	PBTR/L 32-3 D60	32	110	24,8	2,4	8	2,41-3,2	65	ED LCMR...GF	
	PBTR/L 32-4 D80	32	110	24,8	3,2	10	3,21-4,2	81	ES LCMR...GM	

Ersatzteile Spare parts	Bestellbezeichnung Ordering code		
 Schlüssel Key	VO7-E1230		

Passende Wendeplatten
Suitable inserts

ED LC...GM/GF	ES LC...GM/GF				

Seiten Pages
18, 19

Seiten Pages
20, 21

Bestellbeispiel Order example: 1 Stück off PBTR 32-2 D42
Schlüssel ist nicht im Lieferumfang enthalten. Bei Bedarf bitte separat bestellen.
Key is not included in the delivery. If necessary, please order separately.

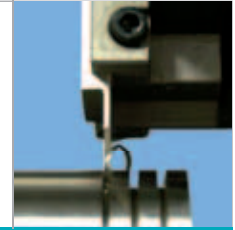

PB (Spannblock) PB (Parting block)	Bestellbezeichnung Ordering code	h₃	h₁	h₂	h₄	h	b₂	l₁	b₁	b	Klingen Suitable blades	
PH.. 	PH 16-26	26	21,0	16	12	38	4,0	87	15	29	PB 26 -	
	PH 20-26	26	21,4	20	8	38	4,0	87	19	33	PB 26 -	
	PH 25-26	26	21,4	25	3	38	4,0	110	20	34		
	PH 20-32	32	24,8	20	13	48	5,5	100	19	35	PB 32 -	
	PH 25-32	32	24,8	25	8	48	5,5	110	20	36	PBTR 32 -	
	PH 32-32	32	24,8	32	3	48	5,5	120	28	44		
	PH 25-45	45	38,1	25	18	66	5,5	120	28	45	PB 45 -	
	PH 32-45	45	38,1	32	18	66	5,5	120	28	45		

Bestellbeispiel Order example: 1 Stück off PH 20-26



	Bestellbezeichnung Ordering code	h	b	l ₁	f	l ₂	b ₁	w	h ₃			Schneideinsatz Inserts
CGFC...E...D 	CGFCR/L 1010 M2 E D33	10	10	150	9,10	31	1,8	1,90-2,4	8	33	33	ED LCMR.GM
	CGFCR/L 1212 M2 E D35	12	12	150	11,10	31	1,8	1,90-2,4	6	35	35	ED LCMR.GF
	CGFCR/L 1212 M3 E D38	12	12	150	10,81	31	2,4	2,41-3,2	6	38	40	ES LCMR.GM
	CGFCR/L 1616 M2 E D35	16	16	150	15,10	31	1,8	1,90-2,4	2	35	35	ES LCMR..GF
	CGFCR/L 1616 M3 E D38	16	16	150	14,81	31	2,4	2,41-3,2	2	38	45	ED LCMR.UM
	CGFCR/L 2012 K2 E D35	20	12	125	11,10	31	1,8	1,90-2,4	0	35	35	
	CGFCR/L 2020 K3 E D38	20	20	125	18,81	31	2,4	2,41-3,2	0	38	45	
	CGFCR/L 2020 K4 E D38	20	20	125	18,40	33	3,2	3,21-4,2	0	38	55	
	CGFCR/L 2525 M3 E D38	25	25	150	23,81	31	2,4	2,41-3,2	0	38	45	
	CGFCR/L 2525 M4 E D38	25	25	150	23,40	33	3,2	3,21-4,2	0	38	55	

Ersatzteile Spare parts	Bestellbezeichnung Ordering code		
	Schlüssel Key		
	VO7-E1230		

Passende Wendeplatten

Suitable inserts

ED LC...GM/GF	ES LC...GM/GF	ED LCMR....UM			

Seiten Pages
18, 19

Seiten Pages
20, 21

Seiten Pages
18

Bestellbeispiel Order example: 1 Stück off CGFCR 1010 M2 E D33

Schlüssel ist nicht im Lieferumfang enthalten. Bei Bedarf bitte separat bestellen
 Key is not included in the delivery. If necessary, please order separately.



	Bestellbezeichnung Ordering code	h_1	b	l_1	f	l_2	b_1	w	h_2	h_3		Schneideinsatz Inserts
CGFC...E...D 	CGFCR/L 1010 K1.4 E D20	10	10	125	9,5	18	1,0	1,4	13,7	-	20	ED LCMR...GM
	CGFCR/L 1212 K1.4 E D24	12	12	125	11,5	19,5	1,0	1,4	15,7	-	24	ED LCMR...GF
	CGFCR/L 1414 K1.4 E D24	14	14	125	13,23	19,5	1,0	1,4	17,7	-	24	ED LCGR...TM
	CGFCR/L 1616 K1.4 E D32	16	16	125	15,23	24	1,0	1,4	19,7	-	32	
	CGFCR/L 1010 K2 E D20	10	10	125	9,23	19	1,55	1,0-3,15	17,5	2	20	
	CGFCR/L 1212 K2 E D24	12	12	125	11,23	19	1,55	1,0-3,15	19,0	2	24	
	CGFCR/L 1414 K2 E D24	14	14	125	13,23	19	1,55	1,0-3,15	19,0	-	24	
	CGFCR/L 1616 K2 E D32	16	16	125	15,23	24	1,55	1,0-3,15	21,0	-	32	

Ersatzteile Spare parts	Bestellbezeichnung Ordering code		
WSP Breite Width of insert	Schraube Screw	Schlüssel Key	Torx
2	1 045 126	V02-T1500	T15

Passende Wendepplatten (*) detaillierte Zuordnung der Halter zu den einzelnen Stechbreiten siehe Seite 49
Suitable inserts (*) detailed assignment of holders to the individual grooving widths see page 49

ED LC...GM/GF	ED LC...TM *)				

Seiten Pages 18, 19 Seite Page 22, 23

Bestellbeispiel Order example: 1 Stück off CGFCR 1212 K2 E D24

Schnittdatenrichtwerte siehe Seiten 62 - 71
 For cutting data standard values see pages 62 - 71



	Bestellbezeichnung Ordering code	h_1	b	l_1	f	l_2	b_1	w	T_{max}	Schneideinsatz Inserts
	CGFCR/L 1616 J2 E12.0	16	16	110	14,95	32,0	1,6	2,00-2,5	12	ED LCMR...GM
	CGFCR/L 1616 J2 E17.0	16	16	110	15,15	37,0	1,6	1,80-2,4	17	
	CGFCR/L 1616 J3 E12.0	16	16	110	14,95	32,0	2,1	2,50-3,5	12	ED LCMR...GF
	CGFCR/L 1616 J3 E20.0	16	16	110	14,90	38,5	2,1	2,41-3,2	20	ED LCMR...GF
	CGFCR/L 1616 J4 E15.0	16	16	110	14,55	32,0	2,9	3,50-4,5	15	ED LC.R...TM
	CGFCR/L 1616 J4 E25.0	16	16	110	14,50	45,0	2,9	3,21-4,2	25	ED RCMR...RU
	CGFCR/L 2020 K2 E12.0	20	20	125	18,95	32,0	1,6	2,00-2,5	12	ED LCMN
	CGFCR/L 2020 K2 E17.0	20	20	125	19,15	37,0	1,6	1,80-2,4	17	ED LCMR...TM
	CGFCR/L 2020 K3 E12.0	20	20	125	18,95	32,0	2,1	2,50-3,5	12	ED RCGN...TM
	CGFCR/L 2020 K3 E20.0	20	20	125	18,90	38,5	2,1	2,41-3,2	20	
	CGFCR/L 2020 K4 E15.0	20	20	125	18,55	32,0	2,9	3,50-4,5	15	ED RCGN...TA
	CGFCR/L 2020 K4 E25.0	20	20	125	18,50	45,0	2,9	3,21-4,2	25	
	CGFCR/L 2020 K5 E20.0	20	20	125	18,05	37,0	3,9	4,50-5,5	20	
	CGFCR/L 2020 K6 E20.0	20	20	125	17,55	37,0	4,9	5,50-6,5	20	ED LCMR...UM
	CGFCR/L 2525 M2 E12.0	25	25	150	23,95	32,0	1,6	2,00-2,5	12	ED RCMR...RU
	CGFCR/L 2525 M2 E17.0	25	25	150	24,15	37,0	1,6	1,80-2,4	17	
	CGFCR/L 2525 M3 E12.0	25	25	150	23,95	32,0	2,1	2,50-3,5	12	
	CGFCR/L 2525 M3 E20.0	25	25	150	23,90	38,5	2,1	2,41-3,2	20	
	CGFCR/L 2525 M4 E15.0	25	25	150	23,55	32,0	2,9	3,50-4,5	15	
	CGFCR/L 2525 M4 E25.0	25	25	150	23,50	45,0	2,9	3,21-4,2	25	
	CGFCR/L 2525 M5 E20.0	25	25	150	23,05	37,0	3,9	4,50-5,5	20	
	CGFCR/L 2525 M5 E32.0	25	25	150	23,00	56,0	3,9	4,21-5,2	32	
	CGFCR/L 2525 M6 E20.0	25	25	150	22,55	37,0	4,9	5,50-6,5	20	
	CGFCR/L 2525 M6 E32.0	25	25	150	23,00	56,0	4,9	5,21-6,2	32	
	CGFCR/L 2525 M8 E25.0	25	25	150	22,05	42,0	5,9	6,50-8,4	25	
CGFCR/L 3232 P8 E25.0	32	32	170	29,05	42,0	5,9	6,50-8,4	25		

Ersatzteile Spare parts	Bestellbezeichnung Ordering code		
WSP Breite Width of insert	Schraube Screw	Schlüssel Key	SW AF
2	M5x16 DIN912	V01-A0040	4
3, 4	M5x16 DIN912	V01-A0040	4
5, 6, 8	M6x25 DIN912	V01-A0050	5

Passende Wendepplatten (*) detaillierte Zuordnung der Halter zu den einzelnen Stechbreiten siehe Seite 49
Suitable inserts (*) detailed assignment of holders to the individual grooving widths see page 49



Seiten Pages
18, 19

Seiten Pages
25

Seite Page
25

Seiten Pages
29

Bestellbeispiel Order example: 1 Stück off CGFCR 1616 J2 E17.0

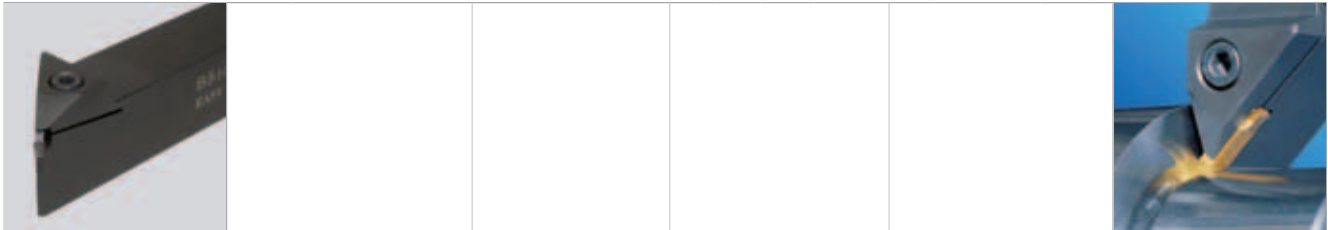

	Bestellbezeichnung Ordering code	h ₁	b	l ₁	f	l ₂	w			Schneideinsatz Inserts
CGSC...E... 	CGSCR/L 1616 J3 E2.8	16	16	110	19,30	30	3,00	2,8	32	ED RCGR...TM
	CGSCR/L 1616 J4 E2.8	16	16	110	19,45	30	4,00	2,8	32	ED RCGR...TA
	CGSCR/L 2020 K3 E2.8	20	20	125	23,30	30	3,00	2,8	32	ED RCMR...RU
	CGSCR/L 2020 K4 E2.8	20	20	125	23,45	30	4,00	2,8	32	
	CGSCR/L 2525 M3 E2.8	25	25	150	28,30	30	3,00	2,8	32	
	CGSCR/L 2525 M4 E2.8	25	25	150	28,45	30	4,00	2,8	32	
	CGSCR/L 2525 M6 E3.4	25	25	150	28,94	35	6,00	3,4	34	

Ersatzteile Spare parts	Bestellbezeichnung Ordering code		
WSP Breite Width of insert	Schraube Screw	Schlüssel Key	SW AF
3	M5x16 DIN912	V01-A0040	4
4	M5x16 DIN912	V01-A0040	4
6	M6x25 DIN912	V01-A0050	5

Passende Wendeplatten
Suitable inserts

ED RC...TM/TA	ED RCMR...RU	ED RC...TA			

Seiten Pages
25

Seiten Pages
25

Seiten Pages
29

Bestellbeispiel Order example: 1 Stück off CGSCR 2020 K4 E2.8



	Bestellbezeichnung Ordering code	h ₁	b	l ₁	f	l ₂	w	T _{max.}	D _{Start}	D _{min}	Schneideinsatz Indexable inserts
CGFC...F...D 	CGFCR/L 2525 M3 F10.0 D30N	25	25	150	23,95	38	3,0	10	35	24	FD LCMR...TM
	CGFCR/L 2525 M3 F10.0 D35N	25	25	150	23,95	38	3,0	10	42	29	FD LCMN...
	CGFCR/L 2525 M3 F10.0 D42	25	25	150	23,95	38	3,0	10	50	36	ED LC.R...TM*)
	CGFCR/L 2525 M3 F15.0 D50N	25	25	150	23,95	38	3,0	15	70	44	ED LCMN...*)
	CGFCR/L 2525 M3 F15.0 D70	25	25	150	23,95	38	3,0	15	100	64	
	CGFCR/L 2525 M4 F10.0 D30	25	25	150	23,55	39	4,0	10	36	22	
	CGFCR/L 2525 M4 F20.0 D36	25	25	150	23,55	39	4,0	20	42	28	
	CGFCR/L 2525 M4 F20.0 D42	25	25	150	23,55	39	4,0	20	50	34	
	CGFCR/L 2525 M4 F20.0 D50	25	25	150	23,55	39	4,0	20	70	42	
	CGFCR/L 2525 M4 F20.0 D70	25	25	150	23,55	39	4,0	20	120	62	
	CGFCR/L 2525 M4 F20.0 D120	25	25	150	23,55	39	4,0	20	200	112	
	CGFCR/L 2525 M5 F25.0 D60	25	25	150	23,05	49	5,0	25	80	50	
	CGFCR/L 2525 M5 F25.0 D80	25	25	150	23,05	49	5,0	25	110	70	
	CGFCR/L 2525 M5 F25.0 D110	25	25	150	23,05	49	5,0	25	150	100	
	CGFCR/L 2525 M5 F25.0 D150	25	25	150	23,05	49	5,0	25	200	140	
	CGFCR/L 2525 M6 F25.0 D60	25	25	150	22,55	49	6,0	25	70	48	
	CGFCR/L 2525 M6 F25.0 D70	25	25	150	22,55	49	6,0	25	100	58	
	CGFCR/L 2525 M6 F25.0 D100	25	25	150	22,55	49	6,0	25	180	88	
CGFCR/L 2525 M6 F25.0 D180	25	25	150	22,55	49	6,0	25	400	168		

Ersatzteile Spare parts	Bestellbezeichnung Ordering code		
WSP Breite Width of insert	Schraube Screw	Schlüssel Key	SW AF
3, 4, 5, 6	M6x25 DIN912	V01-A0050	5

*) D_{min} = 60 mm

Passende Wendeplatten
Suitable inserts

FD LC...TM	ED LC...TM				

Seite Page
26

Seiten Pages
23, 24

Bestellbeispiel Order example: 1 Stück off CGFCR 2525 M3 F10.0 D30N

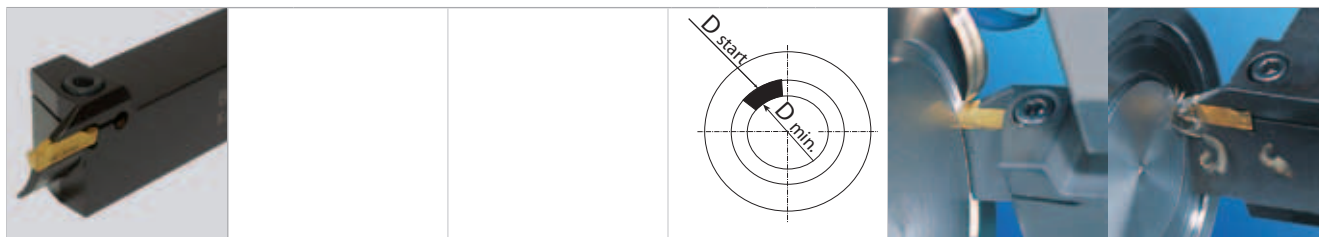

	Bestellbezeichnung Ordering code	h_1	b	l_1	f	l_2	w		D_{START}	Schneideinsatz Inserts
CGFC...F...D 	CGFCR/L 2525 M3 F10.0 D30	25	25	150	23,95	38	3,0	10	30-35	FD LCMR...TM
	CGFCR/L 2525 M3 F10.0 D35	25	25	150	23,95	38	3,0	10	35-40	FD LCMN...
	CGFCR/L 2525 M3 F10.0 D40	25	25	150	23,95	38	3,0	10	40-50	ED LC.R...TM *)
	CGFCR/L 2525 M3 F15.0 D50	25	25	150	23,95	38	3,0	15	50-60	ED LCMN... *)
	CGFCR/L 2525 M3 F15.0 D60	25	25	150	23,95	38	3,0	15	60-85	
	CGFCR/L 2525 M4 F12.0 D30	25	25	150	23,55	32	4,0	12	30-40	
	CGFCR/L 2525 M4 F15.0 D40	25	25	150	23,55	32	4,0	15	40-50	
	CGFCR/L 2525 M4 F15.0 D50	25	25	150	23,55	32	4,0	15	50-60	
	CGFCR/L 2525 M4 F15.0 D60	25	25	150	23,55	32	4,0	15	60-85	
	CGFCR/L 2525 M6 F20.0 D60	25	25	150	22,55	37	6,0	20	60-85	
	CGFCR/L 2525 M6 F20.0 D85	25	25	150	22,55	37	6,0	20	80-150	
	CGFCR/L 2525 M6 F20.0 D150	25	25	150	22,55	37	6,0	20	150-250	

Rechtsausführung dargestellt

Ersatzteile Spare parts	Bestellbezeichnung Ordering code		
WSP Breite Width of insert	Schraube Screw	Schlüssel Key	SW AF
4	M5x16 DIN912	V01-A0040	4
4	M5x16 DIN912	V01-A0040	4
6	M6x25 DIN912	V01-A0050	5

*) $D_{min} = 60$ mm

Passende Wendepplatten
Suitable inserts

FD LC...TM	ED LC...TM				

Seite Page
26

Seiten Pages
23,24

Bestellbeispiel Order example: 1 Stück off CGFCR 2525 M4 F12.0 D30

Systembilder



	Bestellbezeichnung Ordering code	h_1	b	l_1	l_2	w	T_{max}	D_{Start}	D_{min}	Schneideinsatz Inserts
	CGACR/L 2525 M3 F10.0 D30	25	25	150	18	3,0	10	35	30	FD LCMR...TM FD LCMN... ED LC.R...TM *) ED LCMN... *)
	CGACR/L 2525 M3 F10.0 D40	25	25	150	18	3,0	10	50	40	
	CGACR/L 2525 M3 F15.0 D50	25	25	150	18	3,0	15	60	50	
	CGACR/L 2525 M3 F15.0 D60	25	25	150	18	3,0	15	85	60	
	CGACR/L 2525 M4 F12.0 D30	25	25	150	18	4,0	12	40	30	
	CGACR/L 2525 M4 F15.0 D40	25	25	150	18	4,0	15	50	40	
	CGACR/L 2525 M4 F15.0 D50	25	25	150	18	4,0	15	60	50	
	CGACR/L 2525 M4 F15.0 D60	25	25	150	18	4,0	15	85	60	
	CGACR/L 2525 M6 F20.0 D60	25	25	150	22	6,0	20	85	60	
	CGACR/L 2525 M6 F20.0 D85	25	25	150	22	6,0	20	150	85	
	CGACR/L 2525 M6 F20.0 D150	25	25	150	22	6,0	20	250	150	

Ersatzteile Spare parts	Bestellbezeichnung Ordering code		
WSP Breite Size of insert	Schraube Screw	Schlüssel Key	SW AF
3	M5x16 DIN912	V01-A0040	4
4	M5x16 DIN912	V01-A0040	4
6	M6x25 DIN912	V01-A0050	5

*) $D_{min} = 60$ mm

Passende Wendeplatten
 Suitable inserts

FD LC...TM	ED LC...TM				

Klemmhalter, Axial u. Radial Einstechen und Stechdrehen, kleine Tiefen
Tool holders for face and radial grooving and groove-turning, small depths

Systembilder

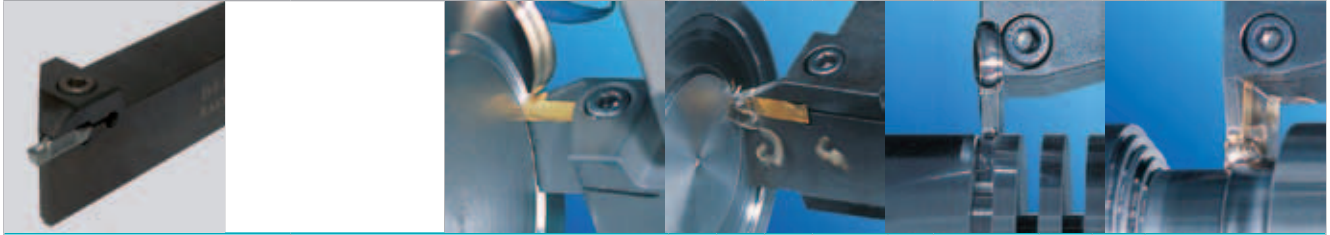

	Bestellbezeichnung Ordering code	h_1	b	l_1	f	l_2	w			Schneideinsatz Inserts
CGFC...F... 	CGFCR/L 1616 J4 F6.0	16	16	110	14,55	32	-4,30	6	30	FD LCMR...TM
	CGFCR/L 2020 K4 F6.0	20	20	125	18,55	32	-4,30	6	30	FD LCMN...
	CGFCR/L 2525 M4 F6.0	25	25	150	23,55	32	-4,30	6	30	ED LC.R...TM *)
	CGFCR/L 2020 K6 F6.0	20	20	125	17,55	37	4,50-6,30	6	60	ED LCMN... *)
	CGFCR/L 2525 M6 F6.0	25	25	150	22,55	37	4,50-6,30	6	60	

Ersatzteile Spare parts	Bestellbezeichnung Ordering code		
WSP Breite Size of insert	Schraube Screw	Schlüssel Key	SW AF
4	M5x16 DIN912	V01-A0040	4
6	M5x25 DIN912	V01-A0050	5

*) $D_{min} = 60 \text{ mm}$

Passende Wendepplatten (*) detaillierte Zuordnung der Halter zu den einzelnen Stechbreiten siehe Seite 49
Suitable inserts (*) detailed assignment of holders to the individual grooving widths see page 49

FD LC...TM	ED LC...TM	ED LC...TM *)			

Seite Page
26

Seiten Pages
23, 24

Seite Page
22

Bestellbeispiel Order example: 1 Stück off CGFCR 2020 K4 F6.0

Systembilder



	Bestellbezeichnung Ordering code	h ₁	b	l ₁		l ₂	w			Schneideinsatz Inserts
CGAC...F...	CGACR/L 2525 M4 F4.8	25	25	150		18	-4,30	4,8	30	FD LCMR...TM
	CGACR/L 2525 M6 F4.8	25	25	150		22	4,50-6,30	4,8	60	FD LCMN...

Ersatzteile Spare parts	Bestellbezeichnung Ordering code		
WSP Breite Width of insert	Schraube Screw	Schlüssel Key	SW AF
4	M5x16 DIN912	V01-A0040	4
6	M5x25 DIN912	V01-A0050	5

Passende Wendeplatten (*) detaillierte Zuordnung der Halter zu den einzelnen Stechbreiten siehe Seite 49
 Suitable inserts (*) detailed assignment at holders of the individual grooving widths see page 49

FD LC...TM	ED LC...TM	ED LC...TM *)			

Seite Page
26

Seiten Pages
23, 24

Seite Page
22

Bestellbeispiel Order example: 1 Stück off CGACR 2525 M4 F4.8



	Bestellbezeichnung Ordering code	d	l ₁	l ₂	f	h ₁	w	b ₁			Schneideinsatz Inserts
A...CGAC...I... 	A20N CGACR/L 2 I6.5	20	160	40	15,8	9,0	2,0	1,55	6,5	25	ID LCGR..TM
	A20N CGACR/L 3 I6.5	20	160	40	15,8	9,0	3,0	2,1	6,5	25	ID LCMN...
	A20N CGACR/L 4 I6.5	20	160	40	15,8	9,0	4,0	2,9	6,5	25	ID RCGR..TM
	A25R CGACR/L 2 I5.8	25	200	40	17,5	11,5	2,0	1,55	5,8	25	ED RCGR..TA*)
	A25R CGACR/L 3 I5.8	25	200	40	17,5	11,5	3,0	2,1	5,8	25	ES RCGN..*)
	A25R CGACR/L 4 I5.8	25	200	40	17,5	11,5	4,0	2,9	5,8	25	
	A25R CGACR/L 5 I6.5	25	200	40	17,5	11,5	5,0	3,9	6,5	31	
	A32S CGACR/L 4 I6.5	32	250	60	20,8	14,0	4,0	2,9	6,5	31	
	A32S CGACR/L 5 I6.5	32	250	60	20,8	14,0	5,0	3,9	6,5	31	
	A32S CGACR/L 6 I6.5	32	250	60	20,8	14,0	6,0	4,9	6,5	31	
	A32S CGACR/L 8 I6.5	32	250	60	21,3	14,5	8,0	5,9	6,5	37	
	A40T CGACR/L 8 I6.5	40	300	65	25,8	19,0	8,0	5,9	6,5	42	

Ersatzteile Spare parts	Bestellbezeichnung Ordering code			Dichtung Seal	Bestellbezeichnung Ordering code	
WSP Breite Width of insert	Schraube Screw	Schlüssel Key	SW AF	Schaft-Ø Shank-Ø	Dichtung Seal	Gewinde Thread
3, 4	M5x16 DIN 912	V01-A0040	4	20	PL20	M6
5, 6, 8	M6x25 DIN 912	V01-A0050	5	25	PL25	R1/8"
				32	PL32	R1/8"
				40	PL40	R1/8"

Passende Wendplatten (*) detaillierte Zuordnung der Halter zu den einzelnen Stechbreiten siehe Seite 49
Suitable inserts (*) detailed assignment of holders to the individual grooving widths see page 49

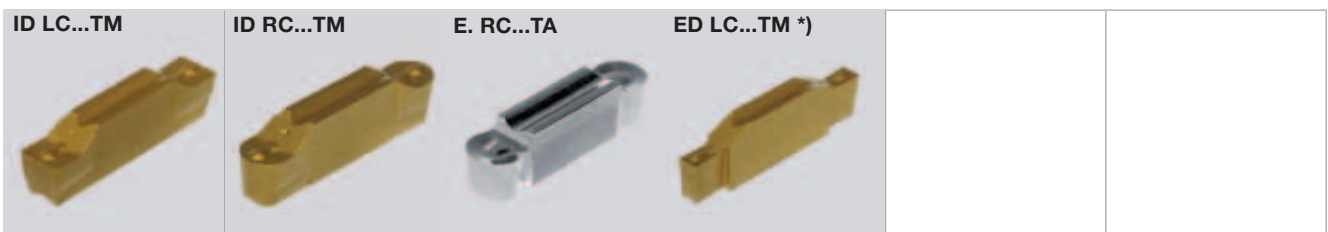

Seite Page
27

Seite Page
28

Seite Page
29

Seite Page
22

Bestellbeispiel Order example: 1 Stück off A20N CGACR 3 I6.5



	Bestellbezeichnung Ordering code	d	l ₁	l ₂	f	h ₁	w		T _{max.}	D _{min.}	Schneideinsatz Inserts
	S20N CGSCR/L 3 I2.8	20	160	-	12,8	9,5	3,0		2,8	38	ID RCGR...TM
	S20N CGSCR/L 4 I2.8	20	160	-	12,9	9,5	4,0		2,8	38	ED RCGR...TM *)
	S25R CGSCR/L 3 I2.8	25	200	40	14,8	11,5	3,0		2,8	38	ED RCGR...TA *)
	S25R CGSCR/L 4 I2.8	25	200	40	14,9	11,5	4,0		2,8	46	
	S25R CGSCR/L 6 I2.8	25	200	-	15,2	11,5	6,0		2,8	46	

*) D_{min} = 60 mm

Ersatzteile Spare parts	Bestellbezeichnung Ordering code		
WSP Breite Width of insert	Schraube Screw	Schlüssel Key	SW AF
20/3	M5x16 DIN 912	V01-A0040	4
20/4,25/3+4	M5x16 DIN 912	V01-A0040	4
25/6	M6x25 DIN 912	V01-A0050	5

Passende Wendeplatten
Suitable inserts



Seite Page
28

Seite Page
25

Seite Page
29

Bestellbeispiel Order example: 1 Stück off A20N CGACR 3 I6.5



	Bestellbezeichnung Ordering code	h	b	l ₁	f	l ₂	b ₁	w	T _{max}	Schneideinsatz Indexable inserts
CGKC...E...	CGKCR/L 2525 M6 E25.0	25	25	150	30	50,5	4,85	6	25	ED RCGR...TA
	CGKCR/L 2525 M8 E30.0	25	25	150	30	55,0	5,85	8	30	

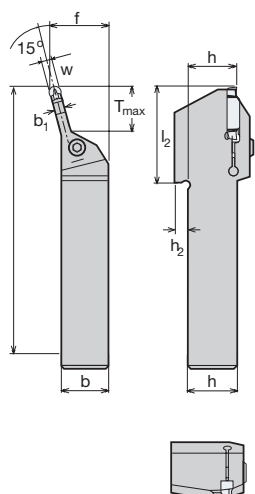

Ersatzteile Spare parts	Bestellbezeichnung Ordering code		
			
WSP Breite Width of insert	Schraube Screw	Schlüssel Key	SW AF
6, 8	M6x25 DIN912	V01-A0050	5

ED RCGR.. TA						
---------------------	--	--	--	--	--	--





	Bestellbezeichnung Ordering code	d	l ₁	l ₂	f	h	w			Schneideinsatz Indexable inserts
S...CGKC...I...	S40T CGKCR/L 6 I50.0	40	300	50	19,76	19	6,0	160	50	ED RCGR..TA
	S40T CGKCR/L 8 I83.0	40	300	60	20,19	19	8,0	160	83	

Ersatzteile Spare parts	Bestellbezeichnung Ordering code		
WSP Breite Width of insert	Schraube Screw	Schlüssel Key	SW AF
6, 8	M6x25 DIN912	V01-A0050	5

ED RCGR.. TA					
---------------------	--	--	--	--	--





Seite Page
29



Bestellbeispiel Order example: 1 Stück off S40T CGKCR 6 I50.0

Sicherungsringeinstiche:
Zuordnung der Werkzeuge zu den Einstechbreiten

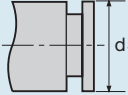

Circlip grooves:

Assignment of tool holders to the individual grooving widths

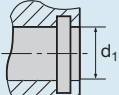
Außeneinstiche External grooves															
		Bestellbezeichnung Ordering code	CGFCR/L...2 E D				CGFCR/L...2 E	CGFCR/L...3 E	CGFCR/L...4 E	CGFCR/L...5 E	CGFCR/L...4 F	CGFCR/L...6 F		CGACR/L...4 F	CGACR/L...6 F
DIN 471 d ₁ mm	DIN 983 d ₁ mm														
7 - 17	16 - 17	ED LCGR 1.00-0.0 TM	●				●	●	●		●			●	
18 - 26	18 - 26	ED LCGR 1.30-0.0 TM	●				●	●	●		●			●	
28 - 35	28 - 35	ED LCGR 1.60-0.1 TM	●				●	●	●		●			●	
36 - 48	36 - 48	ED LCGR 1.85-0.1 TM	●				●				●			●	
50 - 63	50 - 62	ED LCGR 2.15-0.1 TM	●				●				●			●	
65 - 82	65 - 80	ED LCGR 2.65-0.1 TM	●				●	●			●			●	
85 - 100	85 - 100	ED LCGR 3.15-0.1 TM	●				●	●			●			●	
105 - 200	110 - 140	ED LCGR 4.15-0.1 TM						●	●		●			●	
210 - 300		ED LCGR 5.15-0.1 TM								●		●			●

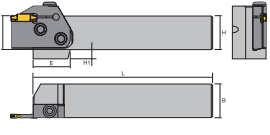
Inneneinstiche Internal grooves						
		Bestellbezeichnung Ordering code	A...CGACR/L...2I	A...CGACR/L...3I	A...CGACR/L...4I	A...CGACR/L...5I
DIN 471 d ₁ mm	DIN 983 d ₁ mm					
25 - 26	25 - 26	ID LCGR 1.30-0.0 TM	●			
28 - 35	28 - 35	ID LCGR 1.60-0.1 TM	●			
36 - 48	36 - 48	ID LCGR 1.85-0.1 TM	●			
50 - 63	50 - 62	ID LCGR 2.15-0.1 TM	●			
65 - 82	65 - 80	ED LCGR 2.65-0.1 TM		●		
85 - 100	85 - 100	ED LCGR 3.15-0.1 TM		●		
105 - 200	110 - 140	ED LCGR 4.15-0.1 TM		●	●	
210 - 300		ED LCGR 5.15-0.1 TM				●

Halter für Adapter Holder for adapter								
XG...-Halter	Bestellbezeichnung Ordering code	h	b	l1	H1	B1	E	H
	XGFCR 2020K	20	20	133	12	-	35	20
	XGFCL 2020K	20	20	133	12	-	35	20
	XGFCR 2525K	25	25	133	7	-	28	25
	XGFCL 2525K	25	25	133	7	-	28	25
	XGFCR 3232P	32	32	153	-	-	28	32
	XGFCL 3232P	32	32	153	-	-	28	32

Halter für Adapter Holder for adapter								
XG...-Halter	Bestellbezeichnung Ordering code	h	b	l1	H1	B1	E	H
	XGACR 2020K	20	20	150	12	8	-	20
	XGACL 2020K	20	20	150	12	8	-	20
	XGACR 2525K	25	25	150	7	3	-	25
	XGACL 2525K	25	25	150	7	3	-	25
	XGACR 3232P	32	32	170	-	-	-	32
	XGACL 3232P	32	32	170	-	-	-	32

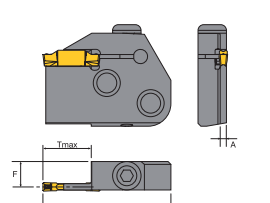
Adapter adapter								
XGFCR/L..	Bestellbezeichnung Ordering code	w	L	A	F	T_{max.}	Halter Holder	
	XGFCR 3-16	3	45	2,2	8,9	16	XGFCR/L2020K XGFCR/L2525K XGFCR/L3232K XGACR/L2020K XGAXR/L2525K XGACR/L3232P	
	XGFCL 3-16	3	45	2,2	8,9	16		
	XGFCR 4-16	4	45	3	8,5	16		
	XGFCL 4-16	4	45	3	8,5	16		
	XGFCR 5-20	5	50	4	8	20		
	XGFCL 5-20	5	50	4	8	20		
	XGFCR 6-20	6	50	5	7,5	20		
	XGFCL 6-20	6	50	5	7,5	20		

Ersatzteile Spare parts	Bestellbezeichnung Ordering code		
			
WSP Breite Width of insert	Schraube Screw	Schlüssel Key	SW AF
3, 4, 5, 6	M6x20 DIN912	V01-A0040	4
		V01-A0050	5

XGFC...		Bestellbezeichnung Ordering code	w	L	F	T _{max}	D _{START}	Platte Insert	Halter Holder
	XGFCR 3F12-D40	3	45	8,9	12	40-55	ED-LCMR..3..GM	XGFCR/L ..	
	XGFCL 3F12-D40	3	45	8,9	12	40-55	ED-LCMR..3..GF	XGACR/L..	
	XGFCR 3F12-D55	3	45	8,9	12	55-75	ES-LCMR..3..GM		
	XGFCL 3F12-D55	3	45	8,9	12	55-75	ES-LCMR..3..GF		
	XGFCR 3F12-D75	3	45	8,9	12	75-100	ED-LCMR..3..UM		
	XGFCL-3F12-D75	3	45	8,9	12	75-100	ED-LCMR..3..TM		
	XGFCR-3F12-D100	3	45	8,9	12	100-140			
	XGFCL-3F12-D100	3	45	8,9	12	100-140			
	XGFCR-3F12-D140	3	45	8,9	12	140-200			
	XGFCL-3F12-D140	3	45	8,9	12	140-200			
	XGFCR-4F16-D50	4	45	8,5	16	50-70	ED-LCMR..4..GM		
	XGFCL-4F16-D50	4	45	8,5	16	50-70	ED-LCMR..4..GF		
	XGFCR-4F16-D70	4	45	8,5	16	70-100	ES-LCMR..4..GM		
	XGFCL-4F16-D70	4	45	8,5	16	70-100	ES-LCMR..4..GF		
	XGFCR-4F16-D100	4	45	8,5	16	100-150	ED-LCMR..4..UM		
	XGFCL-4F16-D100	4	45	8,5	16	100-150	ED-LCMR..4..TM		
	XGFCR-4F16-D150	4	45	8,5	16	150-250			
	XGFCL-4F16-D150	4	45	8,5	16	150-250			
	XGFCR-5F20-D55	5	49	8	20	55-80	ED-LCMR..5..GM		
	XGFCL-5F20-D55	5	49	8	20	55-80	ED-LCMR..5..GF		
	XGFCR-5F20-D80	5	49	8	20	80-120	ES-LCMR..5..GM		
	XGFCL-5F20-D80	5	49	8	20	80-120	ES-LCMR..5..GF		
	XGFCR-5F20-D180	5	49	8	20	180-300	ED-LCMR..5..UM		
	XGFCL-5F20-D180	5	49	8	20	180-300	ED-LCMR..5..TM		
	XGFCR-6F25-D60	6	55	7,5	25	60-90	ED-LCMR..6..GM		
	XGFCL-6F25-D60	6	55	7,5	25	60-90	ED-LCMR..6..GF		
	XGFCR-6F25-D90	6	55	7,5	25	90-150	ES-LCMR..6..GM		
	XGFCL-6F25-D90	6	55	7,5	25	90-150	ES-LCMR..6..GF		
XGFCR-6F25-D150	6	55	7,5	25	150-250	ED-LCMR..6..UM			
XGFCL-6F25-D150	6	55	7,5	25	150-250	ED-LCMR..6..TM			
XGFCR-6F25-D250	6	55	7,5	25	250-400				
XGFCL-6F25-D250	6	55	7,5	25	250-400				

Ersatzteile Spare parts	Bestellbezeichnung Ordering code		
WSP Breite Width of insert	Schraube Screw	Schlüssel Key	SW AF
3, 4, 5, 6	M6x20 DIN912	V01-A0040	4
		V01-A0050	5

Achtung:

Nur beim Axialstechen: Rechter Adapter in linken Grundhalter!

Maschine
Machine

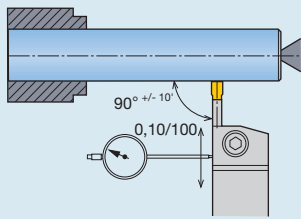

Stellen Sie sicher, dass das Werkzeug exakt unter 90° auf das Teil steht. Eine Abweichung von +/- 10' sollte nicht überschritten werden. Sie erreichen dadurch Planebenheit und reduzieren Vibrationsneigung.

Ensure, that the tool is exactly 90° to the work piece. The difference should be no greater than 10' to achieve straightness and reduce the tendency to cause vibration.

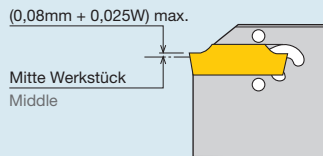

(0,08mm + 0,025W) max.

Mitte Werkstück
Middle

Die Schneidkante sollte ca. 0,1 mm über Mitte liegen. Maximal 0,08 mm + 2.5% Stechbreite w. Vorteilhaft beim Abstechen von Vollmaterial.

The cutting edge should be about 0,1 mm over the middle, maximal 0,08 mm + 2,5 % grooving width w. advantageous in parting of solid material.

Werkzeug
Tool

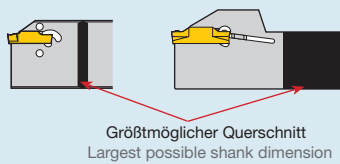

Größtmöglicher Querschnitt
Largest possible shank dimension

Wählen Sie die Klinge oder den Halter mit dem größtmöglichen Schaftquerschnitt. Sie erhöhen dadurch die Maßgenauigkeit und reduzieren Vibrationsneigung.

Choose the blade or tool holder with the largest possible shank dimension. Increase precision and reduce tendency to cause vibration.

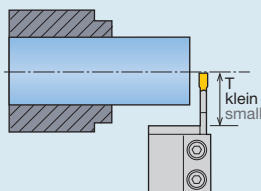

T klein
small

Wählen Sie die kleinstmögliche Auskrragung. Wir empfehlen Auskrragung T maximal Schafthöhe. Sie reduzieren dadurch Vibrationen und Ablenkung.

Choose the least possible overhang. We recommend overhang T maximum to shank height. Reduce vibrations and deflection.

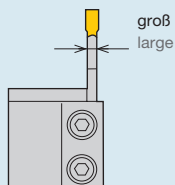



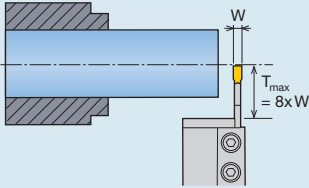
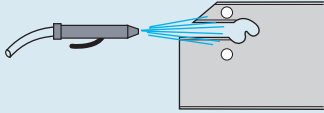

groß
large

Für gute Stabilität wählen Sie eine möglichst breite Stechklinge (eine möglichst große Plattenbreite).

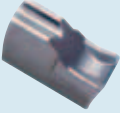
Sie reduzieren dadurch Ablenkung. For good stability choose an insert as wide as possible. Reduce deflection.

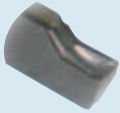
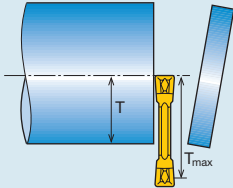
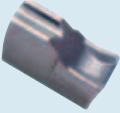
	<p>Maximale Stechtiefe ~ 8 mal Stechbreite W bei gerader Schneide. Sonst ca. 5 - 6 mal W. Sie reduzieren dadurch Vibrationen und Ablenkung. Maximum grooving depth ~ 8x grooving width W with straight cutting edge. Otherwise about 5 - 6x W. Reduce vibrations and deflection.</p>
	<p>Reinigen Sie bei jedem Schneidenwechsel den Plattensitz. Sie erhöhen dadurch die Standzeit. Clean the insert seat when the insert is changed. Increase the tool life.</p>

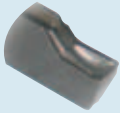
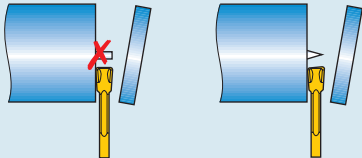
<p>Schneidplatte Insert</p>	
<div style="display: flex; justify-content: space-around;"> <div style="text-align: center;"> <p>GM</p>  </div> <div style="text-align: center;"> <p>GF</p>  </div> <div style="text-align: center;"> <p>UM</p>  </div> </div>	<p>Plattentype: Wählen Sie eine Schneidplatte mit der Geometrie GM oder GF zum Ein- und Abstechen. Sie erreichen damit eine kontrollierte Spanausbringung. Wenn sie mit einer Cermet-Sorte arbeiten, wählen Sie den Universalspanformer UM. Insert type: Choose an insert with the geometry GM or GF for parting and grooving. Have a controlled chip removal. Use the universal chip former UM when working with a Cermet grade.</p>
	<p>Wenn die Eintauchtiefe T_{max} nicht übersteigt, wählen Sie eine zweiseitige Platte: S... Single (einseitig), D... Double (zweiseitig). Sie reduzieren damit Ihre Schneidstoffkosten. If the depth of immersion doesn't pass T_{max}, choose a double ended insert: S... Single (single ended), D... Double (double ended). Reduce your cost for cutting materials.</p>
<div style="display: flex; justify-content: space-around;"> <div style="text-align: center;"> <p>GM</p>  <p>Universell Universal</p> </div> <div style="text-align: center;"> <p>GF</p>  <p>Dünnwandige Teile Parts with thin walls</p> </div> <div style="text-align: center;"> <p>UM</p>  <p>Universal Mittel Universal medium</p> </div> </div>	<p>Für die allgemeine Stahlbearbeitung wählen Sie die Geometrie GM oder UM. Bei dünnwandigen Teilen und Rohren empfehlen wir die schärfere Geometrie GF. Sie erreichen dadurch kürzere Bearbeitungszeiten und längere Standzeiten. For the general steel machining choose the geometry GM. In case of thin-walled parts and tubes we recommend the sharper geometry GF. Have a shorter machining time and a longer tool life.</p>
	<p>Schräge Schneiden reduzieren Grat- und Butzenbildung. So vermeiden Sie Nacharbeitskosten. Angled cutting edges reduce the formation of sharp edges and burrs. Avoid costs for remachining.</p>

Bearbeitung
Machining

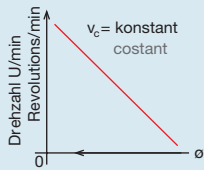

Arbeiten Sie mit konstanter Schnittgeschwindigkeit.
So arbeiten Sie ständig mit optimalen Schnittwerten.
Work with a constant cutting speed to work with optimized cutting values.

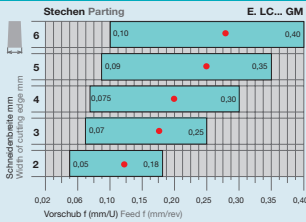

Bei erstmaligem Einsatz beginnen Sie mit den Schnittwerten aus den Tabellen. Sie greifen damit auf die Erfahrungen anderer zurück.
On your first application, begin with the cutting values from the table. So you can use the experience of others.

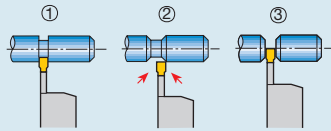

Hinweis: So erzeugen Sie gefaste Abstiche.
Hint: So you produce grooves with chamfer.

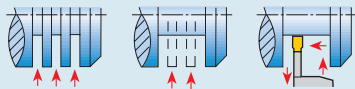

Hinweis: So kammern Sie aus.
Hint: So you have internal profiling.

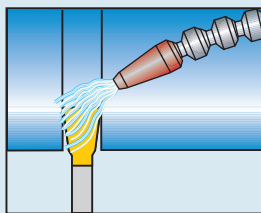

Arbeiten Sie mit Kühlung, Sie erreichen damit höhere Standzeiten und bessere Oberfläche.
Work with coolant to enjoy longer tool life and a better surface finish.

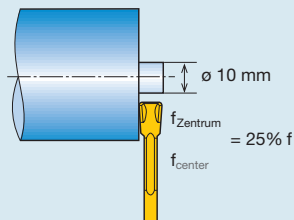

Reduzieren Sie den Vorschub im Zentrum ab Ø 10 mm.
So vermeiden Sie Plattenbruch im Zentrum.
Reduce the feed in the centre from Ø 10 mm to avoid insert breakage in the centre.

Maschine
Machine

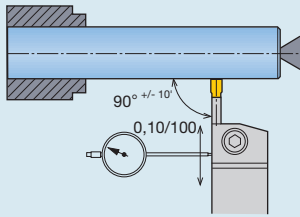

Stellen Sie sicher, dass das Werkzeug exakt unter 90° auf das Teil steht. Eine Abweichung von 10' sollte nicht überschritten werden. Sie erreichen dadurch Planebenheit und reduzieren Vibrationsneigung.

Ensure, that the tool is exactly 90° to the work piece. There should not be a bigger difference than 10' to achieve straightness and reduce the tendency to cause vibration.

Werkzeug
Tool



Größtmöglicher Querschnitt
Largest possible shank dimension

Wählen Sie den Halter mit dem größtmöglichen Schaftquerschnitt. Sie erhöhen dadurch die Maßgenauigkeit und reduzieren Vibrationsneigung.

Choose the tool holder with the largest possible shank dimension. Increase the precision and reduce the tendency to cause vibration.

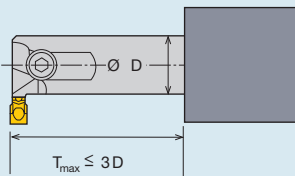

Wählen Sie die kleinstmögliche Auskrägung.

Wir empfehlen Auskrägung T maximal 3 mal Schafthöhe (Schaftdurchmesser). Sie reduzieren dadurch Vibrationen und Ablenkung.

Choose the least possible overhang, we recommend overhang T maximal 3 x shank height (shank diameter). Implementing this method you reduce vibration and deflection.

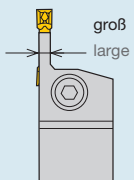

Für gute Stabilität wählen Sie ein möglichst breites Stechschwert (eine möglichst große Plattenbreite).

Sie reduzieren dadurch Vibrationen und Ablenkung.

For good stability choose the insert width as big as possible. Reduce vibration and deflection.

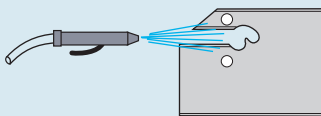

Reinigen Sie bei jedem Schneidenwechsel den Plattensitz.

Sie erhöhen dadurch die Standzeit.

Clean the insert seat when the insert is changed.

Increase the tool life.

**Schneidplatte
Insert**

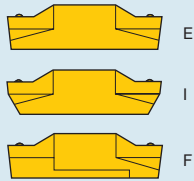

Plattentype: Wählen Sie je nach Bearbeitung die passende Schneidplatte: E... External (außen radial), I... Internal (innen radial), F... Facing (stirnseitig). Die Schneiden wurden auf den jeweiligen Einsatz abgestimmt.
Insert type: choose the appropriate insert according to the machining. E... External, I... Internal, F... Facing.
The cutting edges were designed for the respective application.

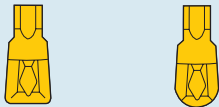

Stechdrehen
Grooveturning

Kopieren, Freistechen
Copy turning, undercutting

Für Kopierdrehen und Schulterfreistriche wählen Sie die runde Schneidenform, sonst die gerade: ..L... Gerade Schneide, ..R... Runde Schneide. So bearbeiten Sie Ihre Teile wirtschaftlich.
For copy turning and shoulder undercuts choose the round cutting edge, otherwise the straight one: ..L... straight cutting edge, ..R... round cutting edge. Machine your parts economically.

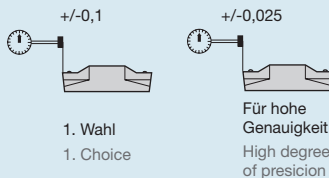

1. Wahl
1. Choice

Für hohe Genauigkeit
High degree of precision

Beginnen Sie mit der direktgepressten Schneidplatte. Die Wechselgenauigkeit ist +/-0,1 mm. ..LCMR... +/- 0,1 mm (direkt gepresst), ..LCGR... +/- 0,025 mm (geschliffen). Sie reduzieren damit Ihre Schneidstoffkosten auf das Minimum.
Begin with the direct pressed insert. The change precision is +/- 0,1 mm. ..LCMR... +/- 0,1 mm (direct pressed), ..LCGR... +/- 0,025 mm (ground). Reduces costs for cutting materials.



Je breiter die Schneide, desto stabiler die Bearbeitung. Sie reduzieren dadurch Vibrationen und Ablenkung.
The wider the cutting edge, the more stable is the machining. Reduces vibration and deflection.

**Bearbeitung
Machining**

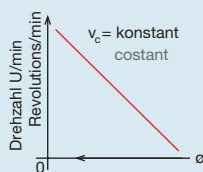

Arbeiten Sie mit konstanter Schnittgeschwindigkeit. So arbeiten Sie ständig mit optimalen Schnittwerten.
Work with a constant cutting speed to work with optimized cutting values.

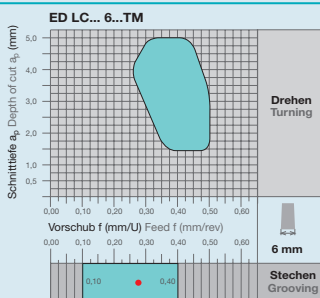

Bei erstmaligem Einsatz beginnen Sie mit den Schnittdaten aus den Tabellen. Sie greifen damit auf die Erfahrungen anderer zurück.
On your first application, you can begin with the cutting values from the table. Use the experience of others.

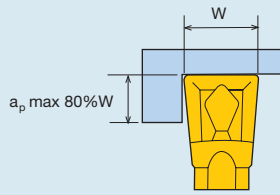

Spantiefe a_p : maximal 80% der Stechbreite.
Cutting depth a_p : maximal 80 % of the cutting width.

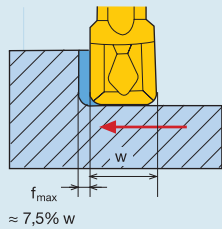

Vorschub f : maximal 7,5% der Plattenbreite, jedoch nicht größer als Eckenradius.
Feed f : maximum 7,5 % of the width of the insert, but not bigger than the corner radius.

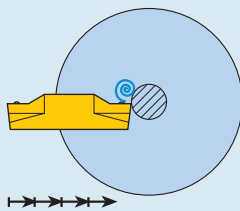

Beim Einstechen bringen kurze Vorschubstops leichtere Spanausbringung. So vermeiden Sie bei tiefen Einstichen Störungen.
By using short feed stops (pecking) you achieve a better swarf control. Avoid chip clogging.

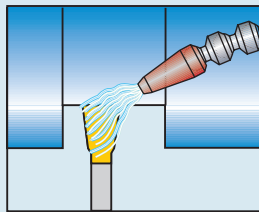

Arbeiten Sie mit Kühlung. Sie erreichen damit höhere Standzeiten und bessere Oberflächen.
Work with coolant. Have a longer tool life and a better surface finish.

Besonderheiten beim Stechdrehen
Peculiarities with groove-turning

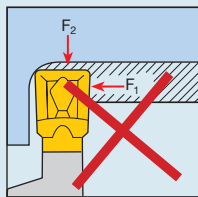

Immer nur eine Schneidkante im Einsatz halten.
So vermeiden Sie Schneidenbruch bei Schnittrichtungsänderung.
Use only one cutting edge.
Avoid edge breakage by changing the cutting direction.

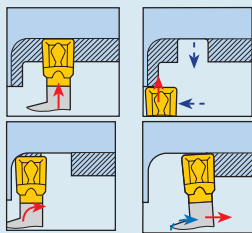

Beim Herstellen von Radien und Fasen Auslauf vorher freistechen.
So vermeiden Sie Schneidenbruch bei Schnittrichtungsänderung.
When producing rads and chamfers produce the undercut first.
Avoid edge breakage by changing the cutting direction.

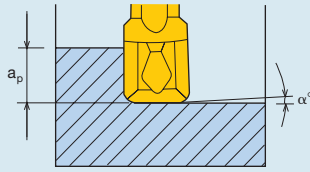

Der Winkel der Wiper-Schneide ändert sich mit dem Schnittdruck.
Die beste Oberfläche erreichen Sie bei mittlerem Schnittdruck.
The angle of the Wiper edge changes with the cutting pressure.
Achieve the best surface with a medium cutting pressure.

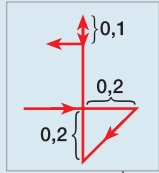

Beim Übergang vom Längsdrehen zum Stechen eine „Freischleife“ von 0,2 mm ziehen, damit sich das Werkzeug zurückstellt.
Vor dem folgenden Übergang vom Stechen zum Längsdrehen das Werkzeug um 0,1 mm zurücksetzen. Mit dieser einfachen Methode nutzen Sie die Vorteile des Stechdrehens prozesssicher.
By changing of longitudinal turning to grooving make a “free loop” of 0.2 mm, so the tool can clear.
Prior to the subsequent change to longitudinal turning set the tool back by 0.1 mm. With this simple method you achieve best advantages of groove-turning.

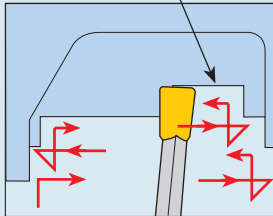

Beim Drehen gegen Schulter Stufen bilden. Diese zum Schluss überdrehen. So vermeiden Sie Schneidenbruch durch Spanschlag.
When machining between shoulders apply near-net-shape technology then over turn. Avoid edge breaking through chip impact.

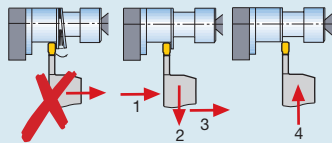

Hängende Ringe vermeiden.
So vermeiden Sie lästige Nacharbeiten.
Avoid hanging rings. Avoid annoying remachining.

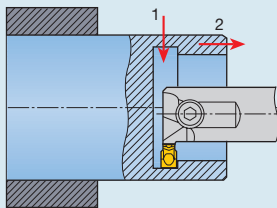

Stechdrehen von Sacklöchern.
So erleichtern Sie die Ausbringung der Späne.
Groove-turning of blind holes. The chip remove is easier.

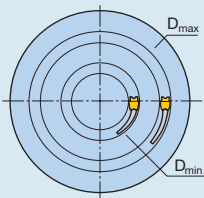

Beim Axialstechen Stechdurchmesserbereich beachten.
Anschließend auf gewünschten Durchmesser drehen.
Die Klinge ist aus Stabilitätsgründen für ausgewählte Durchmesser entwickelt.
When face grooving pay attention to the minimum grooving diameter. Then turn to the required diameter.
The blade is developed for selected diameter because of stability.

Abhilfe Option	Problem Problem														
	Extremer Freiflächenverschleiß Extreme flank wear	Extremer Kolkverschleiß Extreme crater wear	Aufbauschneidendenbildung Formation of built-up edge	Schneidkantenausbrüche fracture of cutting edge	Kerbverschleiß Notch wear	Plattenbruch Breakage insert	Wärmerisse Heat cracks	Plastische Verformung Plastic deformation	Unterbrochener Schnitt Interrupted cut	Schlechte Werkstückoberfläche Poor workpiece surface	Band- / Wirrspan (nicht angelauten) Band/snarl chips (not coloured)	Span blau anlaufen Blue chip	Zu großer Butzen To big burrs	Vibrationen Vibrations	Dünnwandige Teile Thin-walled parts
HM-Verschleißfestigkeit T/C wear resistance	↑				↑		↑								
HM-Zähigkeit T/C toughness				↑		↑	↑		↑					↑	
Schnittgeschwindigkeit Cutting speed	↓	↓	↑		↓			↓	↓	↑					
Vorschub Feed	↔	↓	↓			↓		↓	↓	↔	↑	↓	↓	↓	↓
Schnitttiefe Depth of cut					↔	↓		↓			↔	↔		↓	↓
Spanwinkel Chip angle				↓		↓		↔						↑	↓
Spanformgeometrie Chip former geometry				↔		↔		↔		↔	↔	↔	↔	↔	↔
Zustand der Schneidkante Condition of cutting edge				↔				↔				↔	↔		
Eckenradius Corner radius						↑		↑	↑					↔	↓
Anstellwinkel Approach angle												↑	↓	↑	
Stabilität Stability				↑		↑		↑						↑	
Werkzeughöhe Tool height				↑		↑		↑						↑	
Werkzeugauskragung Tool overhang				↓		↓		↓						↓	
Kühlung Cooling		↑	↑				↑	↑		↑					
Freischleife Free loop				↑		↑									
Plattengröße Insert size						↑								↔	↓

↑ erhöhen, vergrößern
increase

↓ vermindern, verkleinern
reduce

↔ optimieren, kontrollieren
optimize

Sorte	ISO	Anwendungsbereich	Werkstoffgruppe						Bearbeitungsverfahren					
			P	M	K	N	S	H	T	M	D	S	G	P
		01 05 10 15 20 25 30 35 40 45 50	Stahl	Rostfrei	Grauguss	NE-Metalle (Al, etc.)	Hoch-warmfest	Harte Werkstoffe	Drehen	Fräsen	Bohren	Gewindebearbeitung	Ein-stechen	Ab-stechen
LC232F	HC-P30		■						●				●	
	HC-M25			□					●				●	
LC242W	HC-P40		■						●				●	●
	HC-M30			□					●				●	●
LC432T	HC-M30		□	□									●	●
	HC-P30		■	□									●	●
	HC-S25			□			■						●	●
LC442W	HC-P40		■										●	●
	HC-M40			□									●	●
LW612	HW-K10				■	■			●				●	●

Anwendungsschwerpunkt
■ Hauptanwendung
● Standardsorte
□ Weitere Anwendung

Gesamtbereich nach ISO 513

Schneidstoffsorten Stechen, Stechdrehen, Einsatzbereiche

Beschichtete Sorten

LC232F (HC-M30, HC-P30, HC-S25, HC-K25)

Hauptsorte zum Stechdrehen von Stahlwerkstoffen und leicht zerspanbarem rostbeständigem Stahl bei mittleren Schnittgeschwindigkeiten, auch bei unterbrochenem Schnitt. Diese Mehrbereichssorte zeichnet sich durch hohe Verschleißfestigkeit und ausgezeichnete Zähigkeitseigenschaften in einem breiten Einsatzspektrum aus.

LC242W (HC-P40, HC-M30)

Universelle Sorte beim Ein- und Abstechen. Zähe Sorte zum Drehen im Bereich der mittleren bis Grobzerspannung von Stahl und Stahlguss, austenitischen Materialien, mit hohem Widerstand gegen Verformung bei guter Verschleißfestigkeit.

LC432T (HC-P30, HC-S25, HC-M30)

Zähe Feinstkornsorte für die Bearbeitung von legierten und rostfreien Materialien sowie Superlegierungen. Auch für die Gussbearbeitung und Stahl geeignet.

LC442W (HC-M40)

Sehr zähe beschichtete Hartmetallsorte zum Ein- und Abstechen, insbesondere von rostfreiem Stahl bei mittleren bis niedrigen Schnittgeschwindigkeiten unter ungünstigen Schnittbedingungen.

Unbeschichtete Sorten

LW612 (HW-K10)

Ideale Hartmetallsorte zum Bearbeiten von kurzspanenden Werkstoffen wie Aluminium, Messing, etc..

Grade	ISO	Range of application 01 05 10 15 20 25 30 35 40 45 50	Group of materials						Application					
			P Steel	M Stainless	K Grey cast iron	N Non-ferrous metals	S High temperature materials	H Hard materials	T Turning	M Milling	D Drilling	S Threading	G Grooving	P Parting
LC242W	HC-P40		■						●				●	
	HC-M30			□					●				●	
LC242W	HC-P40		■						●				●	●
	HC-M30			□					●				●	●
LC432T	HC-M30		□	□									●	●
	HC-P30		■	□									●	●
	HC-S25			□			■						●	●
	HC-K25		□		■								●	●
LC442W	HC-P40		■										●	●
	HC-M40			□									●	●
LW612	HW-K10				■	■	□		●				●	●
Application peak Full range to ISO 513		01 05 10 15 20 25 30 35 40 45 50	■ Main application □ Further applications						● Standard grade					

Cutting materials grooving, groove-turning, Application possibilities

Coated Grades

LC232F (HC-M30, HC-P30, HC-S25, HC-K25)

Main grade for the groove-turning of steel materials and easy machinable stainless steels with a medium cutting speed, also by interrupted cut. This grade for different areas has a high wear resistance and excellent toughness characteristic in a wide application spectrum.

LC242W (HC-P40, HC-M30)

Universal grade for parting and grooving. Tough grade for medium to rough cutting of steel and cast steel, austenitic materials with high resistance against deformation combined with a good wear resistance.

LC432T (HC-P30, HC-S25, HC-M30)

Tough submicron grade for machining alloyed and stainless materials as well as super alloys. Also applicable for cast iron

LC442W (HC-M40)

Very tough coated carbide grade for parting and grooving, especially of stainless steels at medium to low cutting speeds under unfavourable cutting conditions.

Uncoated grades

LW612 (HW-K10)

Ideal carbide grade for machining of materials with short chips, e.g. aluminium, brass, etc.

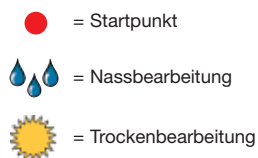

Werkstoff-Gruppe	Gliederung der Werkstoff-Hauptgruppen und Kennbuchstaben		Brinell Härte HB	LC242W f = mm/U  Schnittgeschwindigkeit v _c = m/min		
	Werkstückstoff			max.	Start	min.
P	Unlegierter Stahl ¹⁾	ca. 0,15%C geglüht	125	170	140	110
		ca. 0,45%C geglüht	190	150	125	100
		ca. 0,45%C vergütet	250	145	120	85
		ca. 0,75%C geglüht	270	140	115	85
		ca. 0,75%C vergütet	300	140	115	65
	Niedrig legierter Stahl ¹⁾	geglüht	180	140	115	85
		vergütet	275	140	105	70
		vergütet	300	110	85	60
		vergütet	350	100	75	50
	Hochlegierter Stahl und hochleg. Werkzeugstahl ¹⁾	geglüht	200	140	105	70
gehärtet und angelassen		325	100	75	50	
Nichtrostender Stahl ¹⁾	ferritisch/martensitisch geglüht	200	150	125	100	
	martensitisch vergütet	240	120	95	70	
M	Nichtrostender Stahl ¹⁾	austenitisch ²⁾ , abgeschreckt	180	130	100	60
K	Grauguss	perlitisch/ferritisch	180			
		perlitisch (martensitisch)	260			
	Gusseisen mit Kugelgraphit	ferritisch	160			
		perlitisch	250			
Temperguss	ferritisch	130				
	perlitisch	230				
N	Aluminium-Knetlegierungen	nicht aushärtbar	60			
		aushärtbar, ausgehärtet	100			
	Aluminium-Gusslegierungen	≤ 12% Si. nicht aushärtbar	75			
		≤ 12% Si. aushärtbar, ausgehärtet	90			
		> 12% Si. nicht aushärtbar	130			
	Kupfer und Kupferlegierungen (Bronze / Messing)	Automatenlegierung Pb>1%	110			
Messing, Rotguss		90				
Bronze, bleifreies Kupfer und Elektrolytkupfer		100				
Nichtmetallische Werkstoffe	Duroplaste					
	Faserverstärkte Kunststoffe					
	Hartgummi					
S	Warmfeste Legierungen	Fe-Basis geglüht	200			
		ausgehärtet	280			
		Ni- oder Co-Basis geglüht	250			
		ausgehärtet	350			
	Titanlegierungen	gegossen	320			
Reintitan						
H	Gehärteter Stahl	gehärtet und angelassen				
		gehärtet und angelassen				
	Hartguss	gegossen	400			
	Gehärtetes Gusseisen	gehärtet und angelassen				

1) und Stahlguss
 2) und austenitische / ferritisch
 3) Rm = Zugfestigkeit in N/mm²
 4) HRC = Rockwellhärte C



LC442W f = mm/U			LW612 f = mm/U		
v _c = m/min			v _c = m/min		
max.	Start	min.	max.	Start	min.
120	95	70			
110	90	65			
95	75	55			
90	70	50			
85	65	45			
100	80	60			
80	65	50			
70	55	40			
55	45	35			
80	65	50			
55	45	35			
120	100	70			
90	70	50			
90	70	50			
			80	70	60
			70	60	50
			85	75	65
			75	60	45
			90	85	75
			95	80	70
			3000	1500	500
			2000	1200	300
			1500	1000	400
			1200	800	300
			1000	500	200
			650	400	250
			1000	500	250
			400	250	150
			120	80	60
			50	35	25
			55	40	30
			30	25	15
			25	20	15
			30	25	15
			160	150	140
			50	40	30
			40	35	30

Die angegebenen Schnittdatenrichtwerte sind Empfehlungen, die jedoch auf Grund von verschiedenen Einflussgrößen wie Werkzeuglänge, Maschinenzustand, Stabilität des Werkstückes etc. an die gegebenen Arbeitsbedingungen angepasst werden müssen.
Als Optimierungsunterstützung siehe Seite 59 „Maßnahmen bei Bearbeitungsproblemen“.

Material group	Main workpiece material groups and their characteristic letters				LC242W f = mm/rev		
	Workpiece material	Brinell hardness HB	Cutting speed $v_c = \text{m/min}$				
			max. 	Start 	min. 		
P	Unalloyed steel ¹⁾	ca 0,15%C annealed	125	170	140	110	
		ca 0,45%C annealed	190	150	125	100	
		ca 0,45%C hardened and temp.	250	145	120	85	
		ca 0,75%C annealed	270	140	115	85	
		ca 0,75%C hardened and temp.	300	140	115	65	
	Low-alloy steel ¹⁾	annealed	180	140	115	85	
		hardened and temp.	275	140	105	70	
		hardened and temp.	300	110	85	60	
		hardened and temp.	350	100	75	50	
	High-alloy steel and high-alloy tool steel ¹⁾	annealed	200	140	105	70	
		hardened and temp.	325	100	75	50	
	Stainless steel ¹⁾	ferritic/martensitic annealed	200	150	125	100	
martensitic hardened and temp.		240	120	95	70		
M	Stainless steel ¹⁾	austenitic ²⁾ , quenched	180	130	100	60	
K	Grey cast iron	perlitic/ferritic	180				
		perlitic (martensitic)	260				
	Nodular graphite cast iron	ferritic	160				
		perlitic	250				
Malleable cast iron	ferritic	130					
	perlitic	230					
N	Aluminium wrought alloys	unhardenable	60				
		hardenable, hardened	100				
	Aluminium cast alloys	≤12% Si. unhardenable	75				
		≤12% Si. hardenable, hardened	90				
		> 12% Si. unhardenable	130				
	Copper and copper alloys (Bronze/Brass)	Free cutting alloys Pb>1%	110				
		Brass, Red bronze	90				
Bronze, non leaded copper and electrolytic copper		100					
Nonmetallic materials	Duroplastics						
	Fibre reinforced plastics						
	Hard rubber						
S	Heat resistant alloys	Fe- based	annealed	200			
			hardened	280			
		Ni- or Co-based	annealed	250			
			hardened	350			
			cast	320			
	Titanium alloys	Pure titanium					
Alpha- and Beta-alloys hardened							
H	Hardened steel	hardened and tempered					
		hardened and tempered					
	Chilled cast iron	cast	400				
Hardened cast iron	hardened and tempered						

1) and cast steel
 2) and austenitic/ferritic
 3) Rm = tensile strength in N/mm²
 4) HRC = Rockwell hardness C

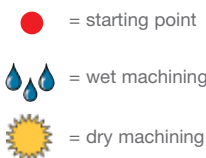



LC442W f = mm/rev			LW612 f = mm/rev		
v _c = m/min			v _c = m/min		
max.	Start	min.	max.	Start	min.
120	95	70			
110	90	65			
95	75	55			
90	70	50			
85	65	45			
100	80	60			
80	65	50			
70	55	40			
55	45	35			
80	65	50			
55	45	35			
120	100	70			
90	70	50			
90	70	50			
			80	70	60
			70	60	50
			85	75	65
			75	60	45
			90	85	75
			95	80	70
			3000	1500	500
			2000	1200	300
			1500	1000	400
			1200	800	300
			1000	500	200
			650	400	250
			1000	500	250
			400	250	150
			120	80	60
			50	35	25
			55	40	30
			30	25	15
			25	20	15
			30	25	15
			160	150	140
			50	40	30
			40	35	30

The cutting data standard values stated are recommendations which have to be adapted to the operating conditions, due to various actuating variables such as tool length, machine condition, workpiece stability and coolant.
See page 59 "Options against machining problems" for optimization.

Werkstoff-Gruppe	Gliederung der Werkstoff-Hauptgruppen und Kennbuchstaben				LC432T f = mm/U 		
	Werkstückstoff	Brinell Härte HB	Schnittgeschwindigkeit v _C = m/min				
			max.	Start	min.		
P	Unlegierter Stahl ¹⁾	ca 0,15%C geglüht	152	170	140	110	
		ca 0,45%C geglüht	190	150	125	100	
	Niedrig legierter Stahl ¹⁾	ca 0,75%C geglüht	252	140	120	85	
		ca 0,75%C vergütet	252	140	120	85	
		geglüht	190	140	120	85	
		vergütet	252	140	110	70	
		vergütet	300	110	80	60	
		vergütet	325	100	80	50	
	M	Nichtrostender Stahl ¹⁾	martensitisch	190	150	120	100
				300	115	90	70
385				100	80	60	
austenitisch			150	130	100	60	
K	Guss	unlegiert	152	130	100	70	
		legiert	175	120	100	70	
			266	100	80	60	
S	Warmfeste Legierungen	Fe-Basis	geglüht	238	100	70	
			ausgehärtet	400			
		Ni- oder Co-Basis	geglüht				
			ausgehärtet				
		gegossen					

- 1) und Stahlguss
- 2) und austenitische/ferritisch
- 3) R_m = Zugfestigkeit in N/mm²
- 4) HRC = Rockwellhärte C

-  = Startpunkt
-  = Nassbearbeitung
-  = Trockenbearbeitung

Die angegebenen Schnittdatenrichtwerte sind Empfehlungen, die jedoch auf Grund von verschiedenen Einflussgrößen wie Werkzeuglänge, Maschinenzustand, Stabilität des Werkstückes etc. an die gegebenen Arbeitsbedingungen angepasst werden müssen.
 Als Optimierungsunterstützung siehe Seite 59 „Maßnahmen bei Bearbeitungsproblemen“.

Material-group	Main workpiece material groups and their characteristic letters		Brinell hardness HB	LC432T $f = \text{mm/U}$ $f = \text{mm/rev}$  Schnittgeschwindigkeit Cutting speed $v_c = \text{m/min}$			
	Workpiece material			max.	Start	min.	
P	Unalloyed steel ¹⁾	ca 0,15%C annealed	152	170	140	110	
		ca 0,45%C annealed	190	150	125	100	
	Low alloy steel ¹⁾	ca 0,75%C annealed	252	140	120	85	
		ca 0,75%C hardened and temp.	252	140	120	85	
		annealed	190	140	120	85	
		hardened and temp.	252	140	110	70	
		hardened and temp.	300	110	80	60	
		hardened and temp.	325	100	80	50	
	M	Stainless steel ¹⁾	martensitic	190	150	120	100
				300	115	90	70
385				100	80	60	
austenitic			150	130	100	60	
K	Casting	unalloyed	152	130	100	70	
		alloyed	175	120	100	70	
		alloyed	266	100	80	60	
S	Heat resistant alloys	Fe-based	annealed	238	100	70	50
			hardened	400			
		Ni- or	annealed				
		Co-based	hardened cast				





- 1) and cast steel
- 2) and austenitic/ferritic
- 3) Rm = tensile strength in N/mm²
- 4) HRC = Rockwell hardness C

 = starting point

 = wet machining

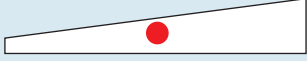
 = dry machining

The cutting data standard values stated are recommendations which have to be adapted to the operating conditions, due to various actuating variables such as tool length, machine condition, workpiece stability and coolant. See page 59 "Options against machining problems" for optimization.



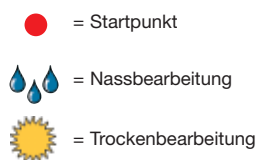

Werkstoff-Gruppe	Gliederung der Werkstoff-Hauptgruppen und Kennbuchstaben			Brinell Härte HB	LC232F f = mm/U  Schnittgeschwindigkeit v _c = m/min		
	Werkstückstoff				max.	Start	min.
							
P	Unlegierter Stahl ¹⁾	ca 0,15%C	geglüht	125	200	170	110
		ca 0,45%C	geglüht	190	190	160	100
		ca 0,45%C	vergütet	250	170	145	85
		ca 0,75%C	geglüht	270	180	150	90
		ca 0,75%C	vergütet	300	170	145	65
	Niedrig legierter Stahl ¹⁾	geglüht		180	180	150	90
		vergütet		275	170	145	85
		vergütet		300	160	140	80
		vergütet		350	125	85	50
	Hochlegierter Stahl und hochleg. Werkzeugstahl ¹⁾	geglüht		200	170	145	85
		gehärtet und angelassen		325	125	85	50
	Nichtrostender Stahl ¹⁾	ferritisch/martensitisch	geglüht	200	170	145	95
		martensitisch vergütet	240	130	115	90	
M	Nichtrostender Stahl ¹⁾	austenitisch ²⁾ , abgeschreckt		180	150	125	100
K	Grauguss	perlitisch/ferritisch		180			
		perlitisch (martensitisch)		260			
	Gusseisen mit Kugelgraphit	ferritisch		160			
		perlitisch		250			
Temperguss	ferritisch		130				
	perlitisch		230				
N	Aluminium-Knetlegierungen	nicht aushärtbar		60			
		aushärtbar, ausgehärtet		100			
	Aluminium-Gusslegierungen	≤ 12% Si. nicht aushärtbar		75			
		≤ 12% Si. aushärtbar, ausgehärtet		90			
		> 12% Si. nicht aushärtbar		130			
	Kupfer und Kupferlegierungen (Bronze/Messing)	Automatenlegierung Pb>1%		110			
		Messing, Rotguss		90			
Nichtmetallische Werkstoffe	Bronze, bleifreies Kupfer und Elektrolytkupfer		100				
	Duroplaste						
	Faserverstärkte Kunststoffe						
S	Warmfeste Legierungen	Fe-Basis	geglüht	200			
			ausgehärtet	280			
		Ni- oder Co-Basis	geglüht	250			
			ausgehärtet	350			
		Titanlegierungen	gegossen		320		
H	Gehärteter Stahl	Reintitan					
		Alpha + Beta-Legierungen, ausgehärtet					
	Hartguss	gehärtet und angelassen					
Gehärtetes Gusseisen	gehärtet und angelassen		400				
	gegossen						

1) und Stahlguss
 2) und austenitische/ferritisch
 3) Rm = Zugfestigkeit in N/mm²
 4) HRC = Rockwellhärte C

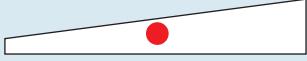

LC242W f = mm/U			LW612 f = mm/U		
v _c = m/min			v _c = m/min		
max.	Start	min.	max.	Start	min.
170	135	110			
160	130	100			
145	120	85			
150	125	90			
145	120	65			
150	125	90			
145	120	85			
140	115	80			
85	70	50			
145	120	85			
85	70	50			
145	120	95			
115	100	90			
125	110	100			
			160	105	80
			120	90	65
			130	100	70
			125	90	65
			140	110	90
			135	105	80
			3000	1500	500
			2000	1200	300
			1500	1000	400
			1200	800	300
			1000	500	200
			650	400	250
			1000	500	250
			400	250	150
			120	80	60
			50	35	25
			55	40	30
			30	25	15
			25	20	15
			30	25	15
			160	150	140
			50	40	30
			40	35	30

Die angegebenen Schnittdatenrichtwerte sind Empfehlungen, die jedoch auf Grund von verschiedenen Einflussgrößen wie Werkzeuglänge, Maschinenzustand, Stabilität des Werkstückes etc. an die gegebenen Arbeitsbedingungen angepasst werden müssen.
Als Optimierungsunterstützung siehe Seite 59 „Maßnahmen bei Bearbeitungsproblemen“.

Material group	Main workpiece material groups and their characteristic letters		Brinell hardness HB	LC232F f = mm/rev  Cutting speed v_c = m/min		
				max. 	Start 	min. 
P	Unalloyed steel ¹⁾	ca 0,15%C annealed	125	200	170	110
		ca 0,45%C annealed	190	190	160	100
		ca 0,45%C hardened and temp.	250	170	145	85
		ca 0,75%C annealed	270	180	150	90
		ca 0,75%C hardened and temp.	300	170	145	65
	Low-alloy steel ¹⁾	annealed	180	180	150	90
		hardened and temp.	275	170	145	85
		hardened and temp.	300	160	140	80
		hardened and temp.	350	125	85	50
	High-alloy steel and high-alloy tool steel ¹⁾	annealed	200	170	145	85
		hardened and temp.	325	125	85	50
	Stainless steel ¹⁾	ferritic/martensitic annealed	200	170	145	95
martensitic hardened and temp.		240	130	115	90	
M	Stainless steel ¹⁾	austenitic ²⁾ , quenched	180	150	125	100
K	Grey cast iron	perlitic/ferritic	180			
		perlitic (martensitic)	260			
	Nodular graphite cast iron	ferritic	160			
		perlitic	250			
Malleable cast iron	ferritic	130				
	perlitic	230				
N	Aluminium wrought alloys	unhardenable	60			
		hardenable, hardened	100			
	Aluminium cast alloys	≤12% Si. unhardenable	75			
		≤12% Si. hardenable, hardened	90			
		> 12% Si. unhardenable	130			
	Copper and copper alloys (Bronze / Brass)	Free cutting alloys Pb>1%	110			
		Brass, Red bronze	90			
Bronze, non leaded copper and electrolytic copper		100				
Nonmetallic materials	Duroplastics					
	Fibre reinforced plastics					
	Hard rubber					
S	Heat resistant alloys	Fe- based	annealed	200		
			hardened	280		
		Ni- or Co-based	annealed	250		
			hardened	350		
		cast	320			
	Titanium alloys	Pure titanium				
Alpha- and Beta-alloys						
hardened						
H	Hardened steel	hardened and tempered				
		hardened and tempered				
	Chilled cast iron	cast	400			
Hardened cast iron	hardened and tempered					

1) and cast steel
 2) and austenitic/ferritic
 3) Rm = tensile strength in N/mm²
 4) HRC = Rockwell hardness C



LC242W f = mm/rev			LW612 f = mm/rev		
v _c = m/min			v _c = m/min		
max.	Start	min.	max.	Start	min.
170	135	110			
160	130	100			
145	120	85			
150	125	90			
145	120	65			
150	125	90			
145	120	85			
140	115	80			
85	70	50			
145	120	85			
85	70	50			
145	120	95			
115	100	90			
125	110	100			
			160	105	80
			120	90	65
			130	100	70
			125	90	65
			140	110	90
			135	105	80
			3000	1500	500
			2000	1200	300
			1500	1000	400
			1200	800	300
			1000	500	200
			650	400	250
			1000	500	250
			400	250	150
			120	80	60
			50	35	25
			55	40	30
			30	25	15
			25	20	15
			30	25	15
			160	150	140
			50	40	30
			40	35	30

The cutting data standard values stated are recommendations which have to be adapted to the operating conditions, due to various actuating variables such as tool length, machine condition, workpiece stability and coolant. See page 59 "Options against machining problems" for optimization.

BOEHLERIT GmbH & Co. KG

Werk VI-Strasse 100
8605 Kapfenberg
Österreich/Austria
Telefon +43 3862 300 - 0
Telefax +43 3862 300 - 793
info@boehlerit.com
www.boehlerit.com

Argentinien/Argentina

SIN PAR S.A.
Conesa 10
B1878KSB Quilmes -
Buenos Aires
Telefon +54 11 4257 4396
Telefax +54 11 4224 5687
ventas@sinpar.com.ar
www.sinpar.net
www.boehlerit.com

Brasilien/Brazil

Boehlerit Brasil Ferramentas Ltda.
Rua Capricórnio, 72
Alphaville Conde I Comercial
06473-005 Barueri
São Paulo
Telefon +55 11 554 60 755
Telefax +55 11 554 60 476
info@boehlerit.com.br
www.boehlerit.com

China/China

LMT China Co. Ltd.
No. 8 Phoenix Road,
Jiangning Development Zone
211100 Nanjing
Telefon +86 25 52103111
Telefax +86 25 52106376
lmt.cn@lmt-tools.com
www.lmt-tools.com
www.boehlerit.com

Deutschland/Germany

Boehlerit GmbH & Co. KG
Werk VI-Strasse 100
8605 Kapfenberg
Österreich/Austria
Telefon +43 3862 300-0
Telefax +43 3862 300-793
info@boehlerit.com
www.boehlerit.com

LMT Tool Systems GmbH
Heidenheimer Straße 84
73447 Oberkochen
Telefon +49 7364 9579-0
Telefax +49 7364 9579-8000
lmt.de@lmt-group.com
www.lmt-tools.com
www.boehlerit.com

Dubai/Dubai

HFD Electronic Spare Parts LLC
The Curve Bldg. SZR
Office M40, P.O. Box 6293
Dubai, United Arab Emirates
Telefon +971 4 380 7866
Telefax +971 4 380 7867
chris@hfdme.ae
www.hfdme.com
www.boehlerit.com

England/United Kingdom

LMT UK Ltd
4202 Waterside Centre,
Solihull Parkway
B37 7YN Birmingham
Telefon +44 16 76 523440
Telefax +44 16 76 525379
lmt.uk@lmt-tools.com
www.lmt-uk.co.uk
www.boehlerit.com

Finnland/Finland

Oy Maantera AB
Keinumäenkuja 2, P.O. Box 70
01510 Vantaa
Telefon +358 29 006 130
Telefax +358 29 006 1130
maantera@maantera.fi
www.maantera.fi
www.boehlerit.com

Frankreich/France

Horn SAS
665 Av Blaise Pascal
77127 Lieusaint
Telefon +33 164 88 5958
Telefax +33 164 88 6049
infos@horn.fr
www.hornfrance.fr

Horn SAS

564 rue Claude Ballaloud
ZAE Bord d'Arve
74950 Scionzier
Telefon +33 4050 183148
Telefax +33 4050 182171
contact@horn.fr

Indien/India

LMT Fette (India) Pvt Ltd
29 (Old No. 14) II Main Road
Gandhinagar, Adyar
Chennai 600 020, India
Telefon +91 44 244 05 136
Telefax +91 44 244 05 205
lmt.in@lmt-tools.com
www.lmt-tools.com
www.boehlerit.com

Italien/Italy

Boehlerit Italy S.r.l.
Via Papa Giovanni XXIII, Nr. 45
20090 Rodano (MI)
Telefon +39 02 269 49 71
Telefax +39 02 218 72 456
info@boehlerit.it
www.boehlerit.com

Mexiko/Mexico

Boehlerit S.A. de C.V.
Av. Acueducto No. 15
Parque Industrial Bernardo
Quintana
El Marqués, Querétaro
México. C.P. 76246
Telefon +52 442 221 5706
Telefax +52 442 221 5555
info@boehlerit.com.mx
www.boehlerit.com

Niederlande/Nederlande

Hagro Precisie b.v.
Industriepark 18
NL-5374 CM Schaijk
Telefon +31 486 462 424
Telefax +31 486 461 650
hagro@hagro.nl
www.hagro.nl
www.boehlerit.com

Polen/Poland

Boehlerit Polska sp.z.o.o.
Złotniki, ul. Kobaltowa 6
62-002 Suchy Las
Telefon +48 61 659 38 00
Telefax +48 61 623 20 14
info@boehlerit.pl
www.boehlerit.com

Russland/Russia

Zerspanung Standard
LMT Tools Ltd.
Serebryanicheskaya nab., 27
Off.101
109028, Moscow
Phone/fax: +7 495 2807 352
www.lmt-russia.ru

MWT-Engineering, Ltd.

5, bld 10, 2nd Enthusiastov str.
111024, Moscow
Telefon +7 495 222 5147
Telefax +7 495 222 5147
a.gorelov@mwt-engineering.ru
www.boehlerit.com

Schweden/Sweden

HORN Sverige & Danmark
Powered by JR TOOL ApS
Box 1902
SE-701 19 Örebro
Telefon + 46 19 / 277 76 06
Telefax +46 19 / 277 76 08
info@phorn.se
www.phorn.se
www.boehlerit.com

Schweiz/Switzerland

Vargus Werkzeugtechnik Snel AG
Knonauerstraße 56
6330 Cham 1
Telefon +41 41 784 21 21
Telefax +41 41 784 21 39
info@vargus.ch
www.vargus.ch
www.boehlerit.com

Singapur/Singapore

Boehlerit Asia Pte Ltd
1 Clementi Loop 04-04
Clementi West District Park
Singapore 12 98 08
Telefon +65 64 624 214
Telefax +65 64 624 215
info@boehleritasia.com
www.boehlerit.com

Slowenien/Slovenia

KAČ trade d.o.o.
Ložnica pri Žalcu 46
3310 Žalec
Telefon: +386 3 710 40 80
Telefax: +386 3 710 40 81
info@kactrade.si
www.kactrade.com
www.boehlerit.com

Spanien/Spain

Boehlerit Spain S.L.
C/. Narcis Monturiol 11-15
08339 Vilassar de Dalt Barcelona
Telefon +34 93 750 7907
Telefax +34 93 750 7925
info@boehlerit.es
www.boehlerit.com

Südkorea/South Korea

LMT Korea Co., Ltd
Room # 1520,
Anyang Trade Center
Bisan-Dong, Dongan-Gu
Anyang-Si, Gyeonggi-Do,
431-817, South Korea
Telefon +82 31 384 8600
Telefax +82 31 384 2121
lmt.kr@lmt-tools.com
www.lmt-tools.com
www.boehlerit.com

Tschechien/Czech Republic

Slowakei/Slovakia
Kancelár Boehlerit
Santraziny 753
760 01 Zlín
Telefon +420 577 214 989
Telefax +420 577 219 061
boehlerit@boehlerit.cz
boehlerit@boehlerit.sk
www.boehlerit.cz
www.boehlerit.sk
www.boehlerit.com

Türkei/Turkey

Böhler Sert Maden
ve Takım San. ve Tic. A.Ş.
Gebze Organize Sanayi Bölgesi
1600. Sk.No: 1602
41480 Gebze – Kocaeli
Telefon +90 262 677 1737
Telefax +90 262 677 1746
bohler@bohler.com.tr
www.boehler.com.tr
www.boehlerit.com

Ungarn/Hungary

Boehlerit Hungária Kft.
PO Box: 2036 Érdliget Pf. 32
2030-Érd, Kis-Duna u.6.
Telefon +36 23 521 910
Telefax +36 23 521 919
info@boehlerit.hu
www.boehlerit.com

USA

Kanada/Canada
LMT USA
1081 S. Northpoint Blvd.
Waukegan, IL 60085
Telefon +1 630 9695412
Telefax +1 630 9695492
lmt.us@lmt-tools.com
www.lmt-tools.com
www.boehlerit.com