

BIGBAG

Filling Machines



BBD SERIES

BIGBAG FILLING MACHINES

BBD Serisi Bigbag Dolum Makinaları



VARLIK MAKİNA
Let's build up your imagine

İletişim Merkezi
0212. 798 26 25

Perfect design for efficient operation
Verimli çalışma için geliştirilmiş tasarım

BBD Series Bigbag filling machines



Digital Control and Display
Dijital Kontrol ve Ekran



Blower for Better Forming
Blower ile Daha İyi Torba Formu

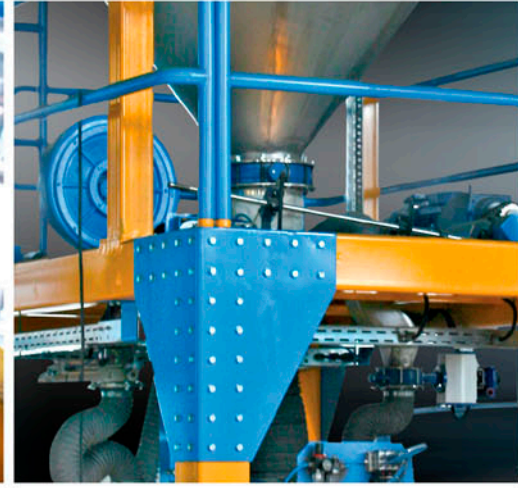

Heavy Duty Structure
Ağır Hizmet Tipi Şase

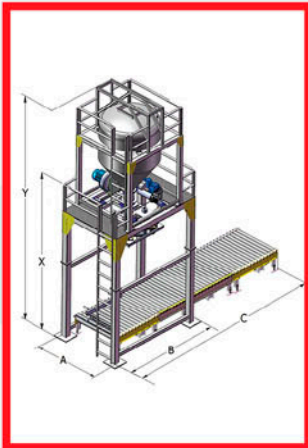

Standard Machine / Standart Makina

Electricity / Elektrik	380V AC, 3 Phase+N+E
Total Power / Toplam Hava	6 kWh (except feeding / Besleme Harıç)
Compressed Air / Basıncılı Hava	6 Bar
Total Air / Toplam Hava	100 N Lt/hour / 1000 Lt/saat

Machine Type Makina Dolum Tipi	A mm	B mm	C mm	X mm	Y mm
Net Weighing Net Tartımlı	1400	2600	5000	-	6500
Gross Weighing Brüt Tartımlı	1400	2600	5000	3500	-
Volumetric Filling Volumetrik Dolum	1400	2600	5000	3500	-

Individual designs for your demands
İhtiyacınıza uygun tasarımlar



BIG (BULK) BAG FILLING MACHINE

VARLIK is an expert on big (bulk) bag filling machines with the improvements over the years and wide experience in this period. We are proud of producing special solutions besides standard big bag machines, depending on speed/product /place /.... of your needs.

Machine Filling Types:

- Big bag filling machines with net weigher,
- Big bag filling machines with gross weigher,
- Big bag machines with volumetric filling

Standard Specifications:

- Automation cabinet with Siemens S7-200 PLC
- Product feeding unit depending on type of product
- Easy hanging height adjustment by operator panel via encoder for the different big bag sizes
- Empty bag blow-up by blower fan for better packing form and effective filling operation
- Automatic operation with one touch start after big-bag placing
- Automatic big bag-loops releasers after filling
- Heavy duty support platform

Optional Specifications:

- Siemens OP 77A operator panel
- Automatic pallet feeding unit
- Automatic big bag exit from filling point by exit conveyor (roller or belt)
- Automatic big bag accumulation by roller or belt conveyor for 2 pc filled big-bags, and automatic traffic control.
- Product feeding solutions (bucket conveyor, vibratory feeder, belt conveyor, screw feeder or pneumatic transport)
- Bag/product vibrating unit for de-aerating to minimize the big-bag size and to produce stand-up bag.
- Stainless steel option for the contact materials with product
- Dust-free filling by jet pulse filtration unit

VARLIK presents highest productivity and best weighing accuracy together with perfect big-bag shapes.



Weighing by Loadcell
Ladcell ile Tartım



Height Adjustment by Encoder
Enkoder ile Yükseklik Ayarı



Automatic Pallet Feeding
Otomatik Palet Besleme

BIGBAG DOLUM MAKİNASI

Varlık Makina big bag dolum makinalarında yıllar boyunca geliştirdiği sistemler ve bu süreçte edindiği geniş tecrübe ile uzman bir firmadır. Uygulamalarınızda ihtiyacınız olan ürün çeşidi/hız/yer durumuna göre sizlere standart big bag makinaları yanında, özel çözümler de üretmenin gururunu duymaktayız.

Dolum Tipleri:

- Net Tartımlı dolum makinası,
- Brüt Tartımlı dolum makinası,
- Volümetrik dolum makinası

Standart Özellikler:

- Siemens S7-200 PLC ile donatılmış otomasyon panosu
- Ürüne uygun besleme ünitesi
- Encoder ile operator panelden çok kolay değişik big bag ölçüleri için askı yüksekliği ayarı
- Daha iyi big bag formu ve efektif dolumu için fan ile boş torba şişirme
- Torba asma sonrası tek butonla otomatik start ile otomatik dolum
- Dolum sonunda otomatik big bag kulpu bırakma
- Ağır hizmet tipi platform

Opsiyonel Özellikler:

- Siemens OP 77A operatör paneli
- Otomatik palet besleme ünitesi
- Dolum noktasından dolu big bag otomatik çıkış transferi (rulolu veya bantlı konveyör ile)
- Bantlı veya rulolu konveyörler ile 2 big bag akümülayson konveyörü, ve otomatik trafik kontrolü
- Ürün transfer ve besleme çözümleri (koyalı elevatör, vibratörlü besleyici, vidalı konveyör, bant konveyör, pnömatik transfer)
- Daha iyi torba şekli ve daha küçük torba ölçüsü sağlamak için, big bag & ürün titreşim ünitesi,
- Ürünle temas eden yüzeylerin paslanmaz çelik olması
- Jet-puls toz toplama ünitesi ile tozumasız dolum

VARLIK mükemmel big bag şekli yanında, en yüksek verimi ve en iyi tartım hassasiyetini sunar.



Perfect design for efficient operation
Verimli çalışma için geliştirilmiş tasarım

 **Follow The
Technology**



VARLIK MAKİNA SANAYİ
İÇ ve DIŞ TİC. LTD. ŞTİ.

Ömerli Mah. Seciye Sok. No:2
Arnavutköy - İSTANBUL / TÜRKİYE
Phone.: +90 212 798 26 25 / 4 Lines
Fax: +90 212 798 26 29
e-mail: info@varlikmakina.com.tr

www.varlikmakina.com.tr

